

Part No. 060232-10, Rev. B
March 2009

OmniSwitch 6855 Series Hardware Users Guide

Alcatel-Lucent 

www.alcatel-lucent.com

**This user guide documents OmniSwitch 6855 Series hardware, including chassis and associated components.
The specifications described in this guide are subject to change without notice.**

Copyright © 2008 by Alcatel-Lucent. All rights reserved. This document may not be reproduced in whole or in part without the express written permission of Alcatel-Lucent.

Alcatel-Lucent® and the Alcatel-Lucent logo are registered trademarks of Alcatel-Lucent. Xylan®, OmniSwitch®, OmniStack®, and Alcatel-Lucent OmniVista® are registered trademarks of Alcatel-Lucent.

OmniAccess™, Omni Switch/Router™, PolicyView™, RouterView™, SwitchManager™, VoiceView™, WebView™, X-Cell™, X-Vision™, and the Xylan logo are trademarks of Alcatel-Lucent.

This OmniSwitch product contains components which may be covered by one or more of the following U.S. Patents:

- U.S. Patent No. 6,339,830
- U.S. Patent No. 6,070,243
- U.S. Patent No. 6,061,368
- U.S. Patent No. 5,394,402
- U.S. Patent No. 6,047,024
- U.S. Patent No. 6,314,106
- U.S. Patent No. 6,542,507
- U.S. Patent No. 6,874,090



**26801 West Agoura Road
Calabasas, CA 91301
(818) 880-3500 FAX (818) 880-3505
support@ind.alcatel.com
US Customer Support—(800) 995-2696
International Customer Support—(818) 878-4507
Internet—service.esd.alcatel-lucent.com**

Contents

	About This Guide	ix
	Supported Platforms	ix
	Who Should Read this Manual?	xi
	When Should I Read this Manual?	xi
	What is in this Manual?	xi
	What is Not in this Manual?	xi
	How is the Information Organized?	xii
	Documentation Roadmap	xii
	Related Documentation	xiv
	Published / Latest Product Documentation	xv
	Technical Support	xv
Chapter 1	OmniSwitch OS6855 Family	1-1
	Chassis Configurations	1-2
	Industrial Grade Features	1-2
	Security Features	1-3
	Applications	1-3
	Availability Features	1-4
	Software Rollback	1-4
	Hot Swapping	1-4
	Hardware Monitoring	1-5
	Backup Power Supplies	1-5
Chapter 2	OmniSwitch 6855 Series Chassis and Hardware Components	2-1
	OmniSwitch 6855 Chassis Configurations	2-1
	OmniSwitch 6855-24	2-4
	OmniSwitch 6855-U24	2-7
	OmniSwitch 6855-14	2-10
	OmniSwitch 6855-U10	2-13
	Status LEDs	2-16
	Rear Panel	2-18
	OS6855-24/OS6855-U24	2-18
	OS6855-14	2-19
	OS6855-U10	2-20
	OS6855-24/U24 Power Supplies	2-21

PS-126I80AC Power Supply	2-22
PS-360I160AC-P Power Supply	2-23
PS-120I80DC48 Power Supply	2-25
PS-100I80DC24 Power Supply	2-26
OS6855-14/U10 Power Supplies	2-27
PS-I40AC Power Brick	2-29
PS-I66AC-P PoE Power Brick	2-30
PS-I40DC2448 Power Brick	2-31
PS-I40DC2448E Power Brick	2-32
PS-75I42DC48-P PoE Power Brick	2-33
UL Recognized Power Supply Table	2-34
Power Supply Shelf	2-35
OS6855-24/U24	2-35
OS6855-14/U10	2-35
AC Power Cords	2-36
Specifications	2-36
DC Power Supply Considerations	2-37
Connecting a DC Power Source	2-37
Installing DC Power Source Wire Leads	2-38
Console Port	2-40
Port Pinouts	2-41
RJ-45 Console Port – Connector Pinout	2-41
10/100 Ethernet Port – RJ-45 Pinout (non-PoE)	2-41
Gigabit Ethernet Port – RJ-45 Pinout	2-41
10/100/1000 Mbps Power over Ethernet Port – RJ-45 Pinout	2-42
Overtemp Condition	2-42
Chapter 3	
Mounting OS6855-24 and OS6855-U24	3-1
General Mounting Recommendations	3-1
Recommended Clearances	3-1
Elevated Operating Ambient Temperatures	3-2
Reduced Air Flow	3-2
Mechanical Loading	3-2
Circuit Overloading	3-2
Reliable Earthing	3-2
Airflow Recommendations	3-3
Chassis Airflow for OS6855-U24	3-4
Installing Power Supplies	3-5
Connecting a Power Supply Directly to the Chassis	3-5
Rack Mounting the Power Supply Tray	3-6
Connecting the Power Supply Cable	3-8
Securing Power Supply Cord	3-9
Hot-Swapping Power Supplies	3-10
Hot-Swapping a Power Supply Directly Connected to the Chassis	3-10
Hot-Swapping a Rack Mounted Power Supply	3-11
Rack-Mounting the Chassis	3-12

	Rack Mounting Steps	3-12
	Table Mounting the Chassis	3-14
Chapter 4	Mounting OS6855-14 and OS6855-U10 Switches	4-1
	Chassis Components	4-1
	General Installation Recommendations	4-2
	Cooling Recommendations	4-2
	Recommended Clearances	4-3
	Mechanical Loading	4-3
	Circuit Overloading	4-3
	Reliable Earthing	4-3
	Power Supply Information	4-4
	Rack-Mounting OS6855-14 and OS6855-U10 Switches	4-5
	General Rack-Mounting Guidelines	4-5
	Positioning the Power Supply Tray(s)	4-5
	Installation	4-5
	Additional Rack Mounting Options	4-12
	Table-Mounting OS6855-14 and OS6855-U10 Switches	4-13
	General Table-Mounting Guidelines	4-13
	Positioning the Power Supply Tray(s)	4-13
	Installation	4-13
	Wall-Mounting OS6855-14 and OS6855-U10 Switches	4-20
	General Wall-Mounting Guidelines	4-20
	Installation	4-21
	Hot-Swapping Power Supplies	4-22
Chapter 5	Booting 6855 Series Switches	5-1
	Booting an OmniSwitch 6855	5-1
	Console Port	5-2
	Serial Connection Default Settings	5-2
	Modifying the Serial Connection Settings	5-2
	Viewing the Power Supply Status	5-4
	Monitoring the Chassis	5-5
	Checking the Overall Chassis Status	5-5
	Checking the Temperature Status	5-5
	Checking the Fan Status	5-6
	Checking the Power Supply Status	5-6
	Automatic Monitoring	5-6
	Additional Monitoring Commands	5-6
	Using LEDs to Visually Monitor the Chassis	5-7
	Installing SFP and XFP Transceivers	5-7
Chapter 6	Installing and Managing Power over Ethernet (PoE)	6-1
	In This Chapter	6-2
	Power over Ethernet Specifications	6-3
	Viewing PoE Power Supply Status	6-4

Configuring Power over Ethernet Parameters	6-5
Power over Ethernet Defaults	6-5
Understanding and Modifying the Default Settings	6-5
Setting the PoE Operational Status	6-5
Configuring the Total Power Allocated to a Port	6-6
Configuring the Total Power Allocated to a Switch	6-6
Setting Port Priority Levels	6-7
Understanding Priority Disconnect	6-8
Setting Priority Disconnect Status	6-8
Disabling Priority Disconnect	6-8
Enabling Priority Disconnect	6-8
Priority Disconnect is Enabled; Same Priority Level on All PD	6-9
Priority Disconnect is Enabled; Incoming PD Port has Highest Priority Level	6-9
Priority Disconnect is Enabled; Incoming PD Port has Lowest Priority Level	6-9
Priority Disconnect is Disabled	6-10
Monitoring Power over Ethernet via CLI	6-11

Appendix A	Regulatory Compliance and Safety Information	A-1
	Declaration of Conformity: CE Mark	A-1
	China RoHS: Hazardous Substance Table	A-2
	Waste Electrical and Electronic Equipment (WEEE) Statement	A-4
	Standards Compliance	A-5
	Safety Agency Certifications	A-5
	EMI/EMC Standards	A-5
	ETS	A-6
	FCC Class A and B, Part 15	A-6
	Canada Class A Statement	A-6
	JATE	A-7
	CISPR22 Class A warning	A-7
	VCCI	A-7
	Class A Warning for Taiwan and Other Chinese Markets	A-7
	NEBS	A-7
	Commerical	A-8
	Industrial	A-8
	Military (Navy, Army, Air Force)	A-8
	Translated Safety Warnings	A-10
	Chassis Lifting Warning	A-10
	Blank Panels Warning	A-10
	Electrical Storm Warning	A-10
	Installation Warning	A-11
	Invisible Laser Radiation Warning	A-11
	Lithium Battery Warning	A-12
	Operating Voltage Warning	A-12
	Power Disconnection Warning	A-13
	Proper Earthing Requirement Warning	A-13
	Read Important Safety Information Warning	A-14
	Restricted Access Location Warning	A-14
	Wrist Strap Warning	A-15

Instrucciones de seguridad en español	A-16
Advertencia sobre el levantamiento del chasis	A-16
Advertencia de las tapaderas en blanco	A-16
Advertencia en caso de tormenta eléctrica	A-16
Advertencia de instalación	A-16
Advertencia de radiación láser invisible	A-16
Advertencia de la batería de litio	A-16
Advertencia sobre la tensión de operación	A-16
Advertencia sobre la desconexión de la fuente	A-16
Advertencia sobre una apropiada conexión a tierra	A-17
Leer “información importante de seguridad”	A-17
Advertencia de acceso restringido	A-17
Advertencia de pulsera antiestática	A-17
Clase de seguridad	A-17
Index	Index-1

About This Guide

This *OmniSwitch 6855 Series Hardware Users Guide* describes your switch hardware components and basic switch hardware procedures.

Supported Platforms

This information in this guide applies to the following products:

- OmniSwitch 6855-24
- OmniSwitch 6855-U24
- OmniSwitch 6855-14
- OmniSwitch 6855-U10

Unsupported Platforms

The information in this guide does not apply to the following products:

- OmniSwitch (original version with no numeric model name)
- OmniSwitch 6600 Family
- OmniSwitch 6800 Series
- OmniSwitch 6850 Series
- OmniSwitch 7700
- OmniSwitch 7800
- OmniSwitch 8800
- OmniSwitch 9000 Series
- OmniStack
- OmniAccess

Who Should Read this Manual?

The audience for this users guide is network administrators and IT support personnel who need to configure, maintain, and monitor switches and routers in a live network. However, anyone wishing to gain knowledge on the OmniSwitch 6855 Series hardware will benefit from the material in this guide.

When Should I Read this Manual?

Read this guide as soon as you are ready to familiarize yourself with your switch hardware components. You should have already stepped through the first login procedures and read the brief hardware overviews in the *OmniSwitch 6855 Series Getting Started Guide*.

You should already be familiar with the very basics of the switch hardware, such as module LEDs and module installation procedures. This manual will help you understand your switch hardware components (e.g., chassis, stacking and cables, backup power supplies, etc.) in greater depth.

What is in this Manual?

This users guide includes the following hardware-related information:

- Descriptions of switch configurations.
- Descriptions of “availability” features.
- Descriptions of chassis types (e.g., the OS6855-U24).
- Instructions for mounting the chassis.
- Descriptions of hardware components (status LEDs, chassis, cables, backup power supplies, etc.).
- Managing a chassis.
- Hardware-related Command Line Interface (CLI) commands

What is Not in this Manual?

The descriptive and procedural information in this manual focuses on switch hardware. It includes information on some CLI commands that pertain directly to hardware configuration, but it is not intended as a software users guide. There are several OmniSwitch 6855 Series users guides that focus on switch software configuration. Consult those guides for detailed information and examples for configuring your switch software to operate in a live network environment. See [“Documentation Roadmap” on page -xii](#) and [“Related Documentation” on page -xiv](#) for further information on software configuration guides available for your switch.

How is the Information Organized?

This users guide provides an overview of OmniSwitch 6855 Series switches, specifications of the hardware components, steps for setting up and managing OmniSwitch 6855 Series switches, and an overview and procedures for managing Power over Ethernet (PoE).

Documentation Roadmap

The OmniSwitch user documentation suite was designed to supply you with information at several critical junctures of the configuration process. The following section outlines a roadmap of the manuals that will help you at each stage of the configuration process. Under each stage, we point you to the manual or manuals that will be most helpful to you.

Stage 1: Using the Switch for the First Time

Pertinent Documentation: *Getting Started Guide*
Release Notes

The *Getting Started Guide* provides all the information you need to get your switch up and running the first time. This guide provides information on unpacking the switch, installing power supplies, unlocking access control, setting the switch's IP address, and setting up a password. It also includes succinct overview information on fundamental aspects of the switch, such as hardware LEDs, the software directory structure, stacking, CLI conventions, and web-based management.

At this time you should also familiarize yourself with the Release Notes that accompanied your switch. This document includes important information on feature limitations that are not included in other user guides.

Stage 2: Gaining Familiarity with Basic Switch Functions

Pertinent Documentation: *Hardware Users Guide*
Switch Management Guide

Once you have your switch up and running, you will want to begin investigating basic aspects of its hardware and software. Information about switch hardware is provided in the *Hardware Users Guide*. This guide provide specifications, illustrations, and descriptions of all hardware components—e.g., chassis, backup power supplies, etc.

The *Switch Management Guide* is the primary user guide for the basic software features on a switch. This guide contains information on the switch directory structure, basic file and directory utilities, switch access security, SNMP, and web-based management. It is recommended that you read this guide before connecting your switch to the network.

Stage 3: Integrating the Switch Into a Network

Pertinent Documentation: *Network Configuration Guide*
Advanced Routing Configuration Guide

When you are ready to connect your switch to the network, you will need to learn how the OmniSwitch implements fundamental software features, such as 802.1Q, VLANs, and Spanning Tree. The *Network Configuration Guide* contains overview information, procedures and examples on how standard networking technologies are configured in the OmniSwitch 6855 Series.

The *Advanced Routing Configuration Guide* includes configuration information for networks using Open Shortest Path First (OSPF).

Anytime

The *OmniSwitch CLI Reference Guide* contains comprehensive information on all CLI commands supported by the switch. This guide includes syntax, default, usage, example, related CLI command, and CLI-to-MIB variable mapping information for all CLI commands supported by the switch. This guide can be consulted anytime during the configuration process to find detailed and specific information on each CLI command.

Related Documentation

The following are the titles and descriptions of all the OmniSwitch 6855 Series user manuals:

- *OmniSwitch 6855 Series Getting Started Guide*

Describes the hardware and software procedures for getting an OmniSwitch 6855 Series switch up and running. Also provides information on fundamental aspects of OmniSwitch software.
- *OmniSwitch 6855 Series Hardware Users Guide*

Detailed technical specifications and procedures for the OmniSwitch 6855 Series chassis and components. This manual also includes comprehensive information on assembling and managing stacked configurations.
- *OmniSwitch CLI Reference Guide*

Complete reference to all CLI commands supported on the OmniSwitch 6800, 6850, 6855, and 9000. Includes syntax definitions, default values, examples, usage guidelines and CLI-to-MIB variable mappings.
- *OmniSwitch AOS Release 6 Switch Management Guide*

Includes procedures for readying an individual switch for integration into a network. Topics include the software directory architecture, image rollback protections, authenticated switch access, managing switch files, system configuration, using SNMP, and using web management software (WebView).
- *OmniSwitch AOS Release 6 Network Configuration Guide*

Includes network configuration procedures and descriptive information on all the major software features and protocols included in the base software package. Chapters cover Layer 2 information (Ethernet and VLAN configuration), Layer 3 information (routing protocols, such as RIP), security options (authenticated VLANs), Quality of Service (QoS), and link aggregation.
- *OmniSwitch AOS Release 6 Advanced Routing Configuration Guide*

Includes network configuration procedures and descriptive information on all the software features and protocols included in the advanced routing software package. Chapters cover multicast routing (DVMRP and PIM-SM), and OSPF.
- *OmniSwitch Transceivers Guide*

Includes SFP and XFP transceiver specifications and product compatibility information.
- *Technical Tips, Field Notices*

Includes information published by Alcatel-Lucent's Customer Support group.
- *Release Notes*

Includes critical Open Problem Re, feature exceptions, and other important information on the features supported in the current release and any limitations to their support.

Published / Latest Product Documentation

All user guides for the OmniSwitch 6855 Series are included on the Alcatel-Lucent public website. This website also includes user guides for other Alcatel-Lucent Enterprise products.

The latest user guides can be found on our website at:

http://www1.alcatel-lucent.com/enterprise/en/resource_library/user_manuals/

Technical Support

An Alcatel-Lucent service agreement brings your company the assurance of 7x24 no-excuses technical support. You'll also receive regular software updates to maintain and maximize your Alcatel-Lucent product's features and functionality and on-site hardware replacement through our global network of highly qualified service delivery partners. Additionally, with 24-hour-a-day access to Alcatel-Lucent's Service and Support web page, you'll be able to view and update any case (open or closed) that you have reported to Alcatel-Lucent's technical support, open a new case or access helpful release notes, technical bulletins, and manuals. For more information on Alcatel-Lucent's Service Programs, see our web page at service.esd.alcatel-lucent.com, call us at 1-800-995-2696, or email us at support@ind.alcatel.com.

1 OmniSwitch OS6855 Family

The Alcatel-Lucent OmniSwitch 6855 family of fixed configuration LAN switches are industrial-grade, managed, Gigabit Ethernet units are designed to operate reliably in severe temperatures, as well as harsh physical and electrical conditions.

Note. Switches in the OmniSwitch 6855 family are fixed configuration, standalone units. Stacking multiple OS6855 switches into a virtual chassis is not supported.

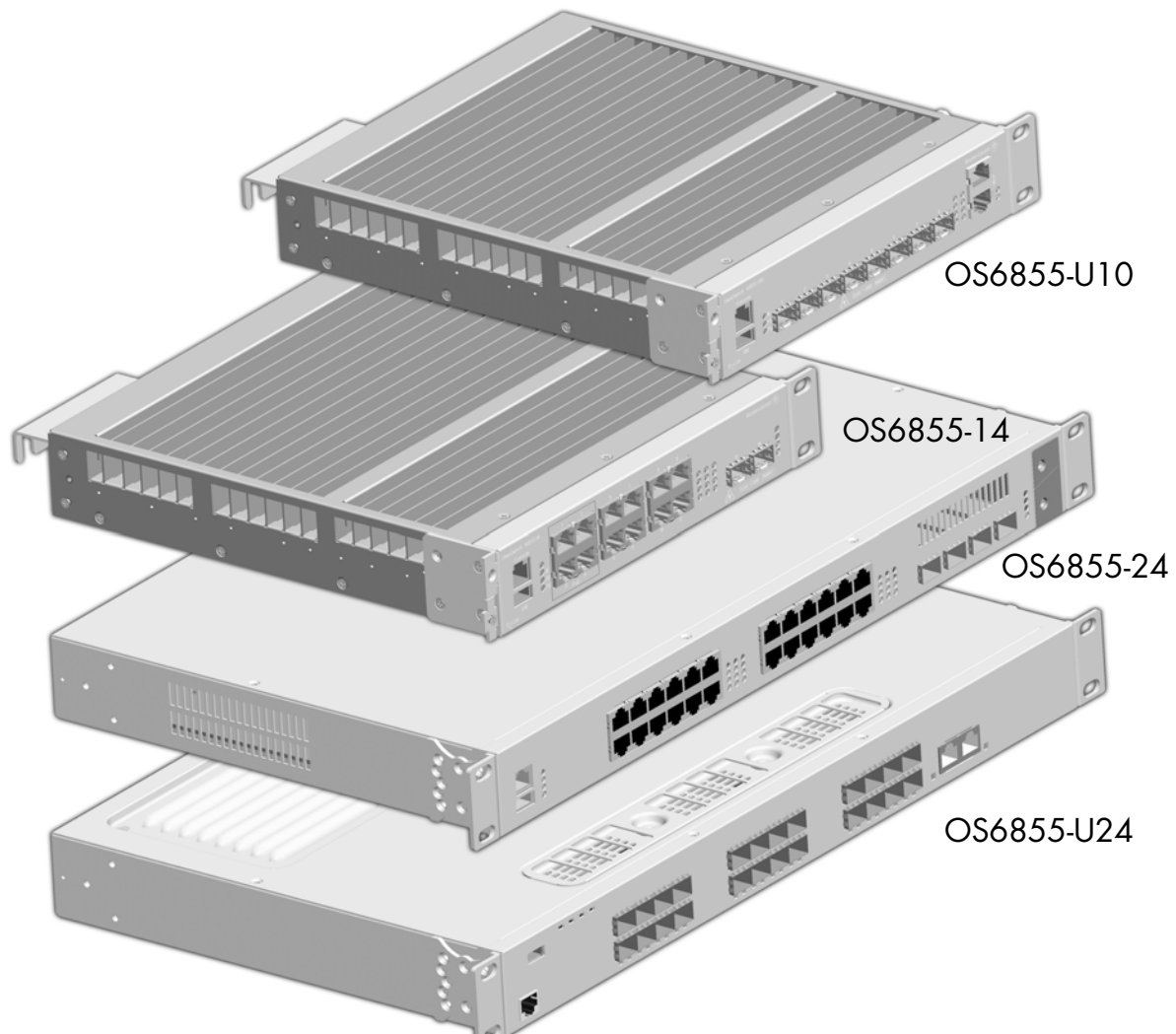

OS6855 Family Industrial-Grade Switches

Chassis Configurations

OmniSwitch 6855 (OS6855) “hardened” switches offer port densities of up to 24 Gigabit Ethernet ports. The following OS6855 chassis configurations are available:

Fiber Models

- OS6855-U10: Provides eight (8) Gigabit Ethernet SFP ports and two (2) RJ-45 10/100/1000 ports.
- OS6855-U24: Provides twenty-two (22) Gigabit Ethernet SFP ports and two (2) combo ports.

Copper Models

- OS6855-14: Provides twelve (12) 10/100/1000 RJ-45 ports and two (2) SFP ports, with four of the 10/100/1000 RJ-45 ports supporting Power over Ethernet.
- OS6855-24: Provides twenty (20) 10/100/1000 RJ-45 ports and four (4) combo ports, with four of the 10/100/1000 RJ-45 ports supporting Power over Ethernet.

Note. Power over Ethernet (PoE) is supported on OS6855-14 and OS6855-24 models only.

Combo Ports

Combo ports are ports individually configurable to be 10/100/1000BaseT or 1000BaseX that can support SFP transceivers for short, long and very long distances.

Gigabit Ethernet Interfaces

Gigabit Ethernet fiber interfaces support Gigabit SFP or 100BaseX SFP optical transceivers.

Industrial Grade Features

- Operates at a wider temperature range (from -40C to +70C for OS6855-14 and OS6855-U10 models and -40C to +75C for OS6855-24 and OS6855-U24 switches).

Note. In over-temperature situations, the switch chassis shuts down and automatically restarts once the temperature is within the normal operating range.

- Withstands greater shock and vibrations
- Enhanced electro-magnetic protection
- Supports a variety of fiber type, including single mode, multi-mode, bidirectional, and long haul optics allowing distances of up to 70 km.
- Diverse power supply options, such as external, redundant, hot swappable, AC and DC
- Flexible mounting provided for table, wall or rack installations

Security Features

For their targeted high impact, mission critical applications, OS6855 switches offer extensive security features for network access control, policy enforcement and attack containment, enabling fully secure networks and OmniVista Network Management System (NMS) support.

Applications

Although well-suited for traditional enterprise network applications, the versatile OS6855 switches are built for high impact applications such as:

- Power utilities
- Military
- Transportation and traffic control systems
- Industrial factories
- Video surveillance systems
- Outdoor installations
- Carrier Ethernet (e.g., Telco, CityNets, Metro access)

Availability Features

OS6855 switches incorporate advanced Alcatel-Lucent Operating System (AOS) protocols to ensure high availability for mission critical applications. Availability features are hardware- and software-based safeguards that help to prevent the loss of data flow in the unlikely event of a subsystem failure.

In addition, some availability features allow users to maintain or replace hardware components without powering off the switch or interrupting switch operations. Combined, these features provide added resiliency and help to ensure that the switch or virtual chassis is consistently available for high-impact network operations.

Hardware-related availability features include:

- [Software Rollback](#)
- [Hot Swapping](#)
- [Hardware Monitoring](#)
- [Backup Power Supplies](#)

Software Rollback

Software rollback (also referred to as *image rollback*) essentially allows the OmniSwitch 6850 Series of switches to return to a prior “last known good” version of software in the event of a system software problem. The switch controls software rollback through its resilient directory structure design (i.e., `/flash/working` and `/flash/certified`).

For detailed information on the software rollback feature, as well as the switch’s `/flash/working` and `/flash/certified` directories, refer to the “Managing CMM Directory Content” chapter in the *Switch Management Guide*.

Hot Swapping

Hot swapping refers to the action of adding, removing, or replacing components without powering off switches or disrupting other components. This feature facilitates hardware upgrades and maintenance and allows users to easily replace components in the unlikely event of hardware failure.

The following OmniSwitch 6855 components can be hot swapped:

- Backup power supplies
- Backup power supply connector cables
- SFPs

Note. For instructions on hot swapping backup power supplies, refer to [Chapter 3, “Mounting OS6855-24 and OS6855-U24”](#) or [Chapter 4, “Mounting OS6855-14 and OS6855-U10 Switches”](#) For instructions on hot swapping combo connector SFPs, refer to the instruction card provided with the SFP.

Hardware Monitoring

Automatic Monitoring

Automatic monitoring refers to the switch's built-in sensors that automatically monitor operations. If an error is detected (e.g., over-threshold temperature), the switch immediately sends a trap to the user. The trap is displayed on the console in the form of a text error message. (In the case of an over-threshold temperature condition, the chassis displays an amber OK LED in addition to sending a trap.)

LEDs

LEDs, which provide visual status information, are provided on the chassis front panel. LEDs are used to indicate conditions such as hardware and software status, temperature errors, link integrity, data flow, etc. For detailed LED descriptions, refer to [Chapter 2, "OmniSwitch 6855 Series Chassis and Hardware Components."](#)

User-Driven Monitoring

User-driven hardware monitoring refers to CLI commands that are entered by the user in order to access the current status of hardware components. The user enters "show" commands that output information to the console. Monitoring information for chassis components, such as the optional back up power supply, chassis temperature sensor, and chassis fans is provided in [Chapter 2, "OmniSwitch 6855 Series Chassis and Hardware Components."](#) The show commands for all the features are described in detail in the *OmniSwitch CLI Reference Guide*.

Backup Power Supplies

OmniSwitch 6855 switches support an optional backup power supply. Backup power supplies operate in active standby mode. If the primary power supply fails unexpectedly, the backup power supply automatically takes up the full power load without disrupting the switch.

The primary and backup power supplies for all OmniSwitch 6855 models are external. The power supplies for OS6855-U10 and OS6855-14 models come in the form of a power "brick." The Power over Ethernet (PoE) brick is separate from the main chassis power supply and is only required if the PoE capabilities of the switch are in use.

Additional Power Supply Details

For OS6855-24 and OS6855-U24 models, a power shelf is provided with the unit. It can slide into the rear of the chassis and is used to hold the primary and the backup power supplies.

Any power supply can be remotely connected using a cable. With this configuration, the same power shelf can be mounted in the rack using a mounting bracket (provided with the unit). This allows the OmniSwitch 6855 to be used in reduced depth areas such as wall-mounted cabinets, etc.

Note. For more information on power supplies, refer to [Chapter 2, "OmniSwitch 6855 Series Chassis and Hardware Components."](#)

2 OmniSwitch 6855 Series Chassis and Hardware Components

OmniSwitch 6855 Chassis Configurations

OmniSwitch 6855 Series switches are available in four chassis configurations as shown in the table below:

- OmniSwitch 6855-24 (OS6855-24) Twenty (20) 10/100/1000 RJ-45 ports and four (4) combo ports,
- OmniSwitch 6855-U24 (OS6855-U24) Twenty-two (22) SFP ports and two (2) combo ports.
- OmniSwitch 6855-14 (OS6855-14) Twelve (12) 10/100/1000 ports and 2 SFP ports
- OmniSwitch 6855-U10 (OS6855-U10) Eight (8) SFP ports and two (2) 10/100/1000 RJ-45 ports

This chapter includes detailed information on these chassis types. Topics include:

- OmniSwitch 6855 Series chassis descriptions
- Technical specifications
- Power Supplies
- Power cords, console port, and pinout specifications

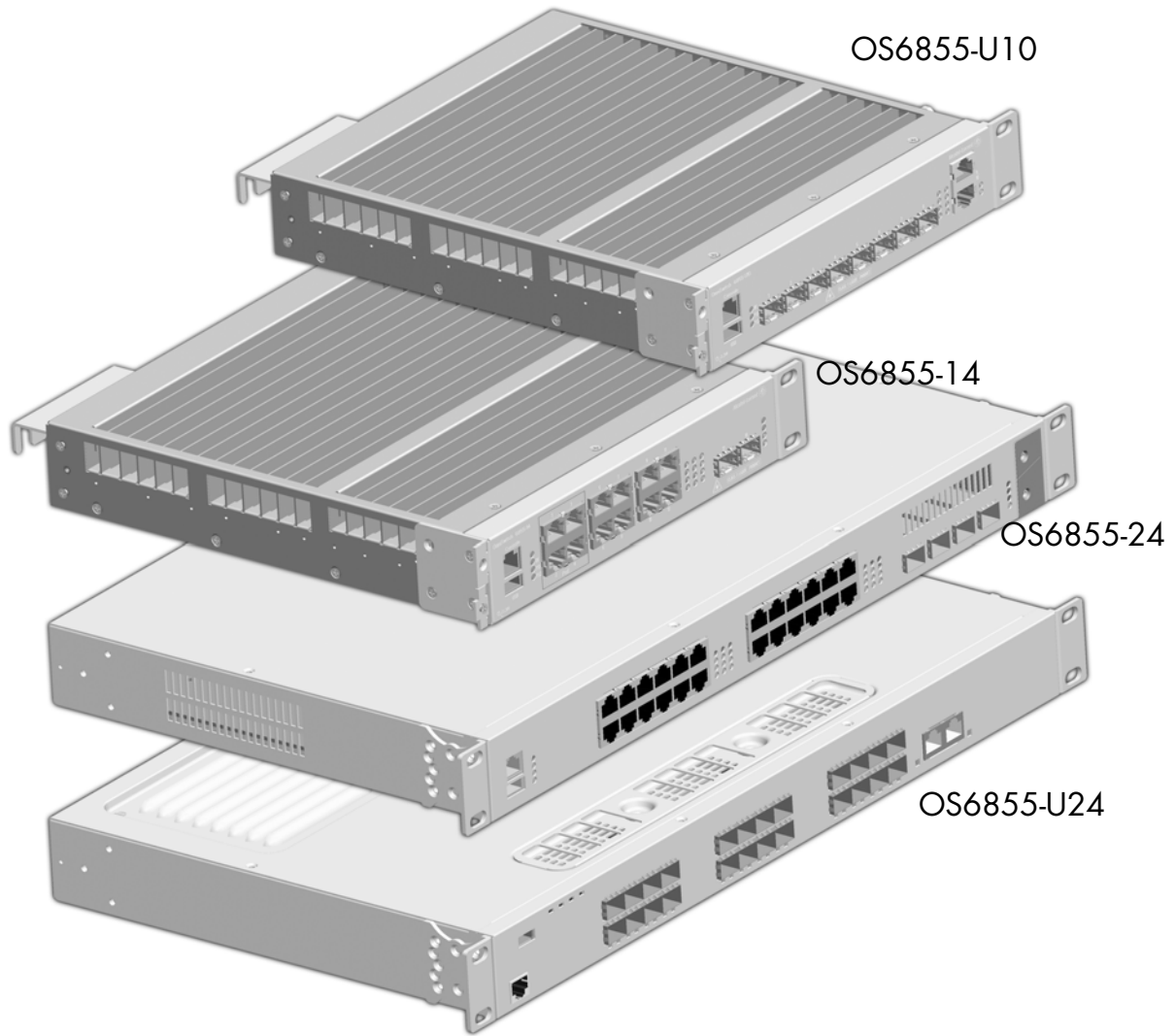

OmniSwitch 6855-24

The OmniSwitch 6855-24 is an edge/workgroup switch offering 20 unshared 10/100/1000Base-T, as well as four combo ports individually configurable to 10/100/1000Base-T or 1000Base-X high-speed connections. Additionally, the first four ports support PoE.

The front panel of the OS6855-24 chassis contains the following major components:

- System status LEDs
- (20) Unshared 10/100/1000Base-T with PoE support on the first four ports
- (4) Combo 10/100/1000Base-T
- (4) Combo SFP connectors
- Console port (RJ-45)
- USB port (USB 2.0)

Note. USB port is not supported in this release.

Refer to the illustration below for more front panel information. For detailed LED descriptions, refer to [page 2-16](#). For information on the chassis rear panel, refer to [page 2-18](#).

Console Port

The OS6855-24 front panel provides one RJ-45 port for console connections. Console connections are used by network administrators for switch management. This female RJ-45 connector provides a DTE console connection.

Status LEDs

For information on the OS6855-24's status LEDs, refer to [page 2-16](#).

10/100/1000Mbps

The OS6855-24 provides 20 fixed 10/100/1000BaseT non-combo (1–20) and 4 fixed 10/100/1000BaseT combo (21–24). These are auto-sensing and auto-MDIX and use RJ-45 connectors. Additionally, the first four ports support PoE.

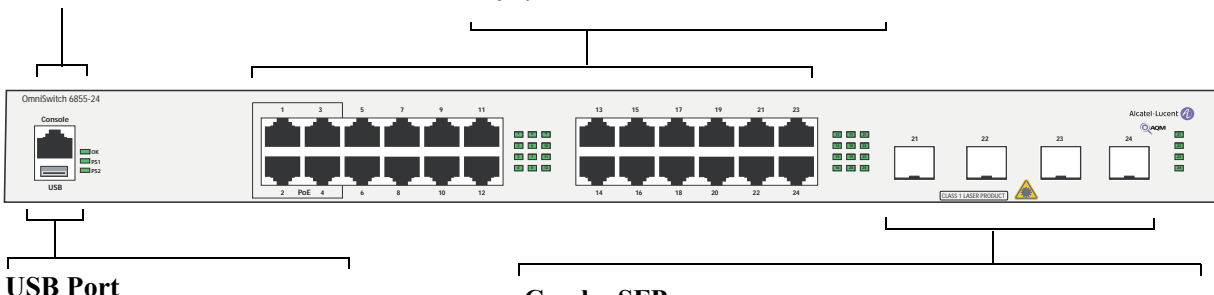

USB Port

Combo SFP

The OS6855-24 provides four combo SFP connectors for user with supported SFP transceivers.

By default, when an SFP is installed in a combo port, it takes over the port number of the corresponding RJ-45 Ethernet port. In other words, if an SFP is installed in the slot labeled 24, Ethernet port 24 would no longer be available and cannot be used for 10/100/1000 traffic. This default setting is referred to as “preferred fiber.” Refer to “Configuring Ethernet” in the *Network Configuration Guide* for detailed information.

OmniSwitch 6855-24 Front Panel

OS6855-24 Specifications	
Total unshared 10/100/1000Base-T per switch (1–20)	20
Total 802.3af PoE ports per switch (1–4)	4
Total shared 10/100/1000Base-T combo per switch (21–24)	4
Total combo SFP connectors per switch (21–24)	4
Flash memory size	128 MB
RAM memory size	256 MB SDRAM
Chassis Width	17.25 inches
Chassis Height	1.73 inches
Chassis Height (rack units)	1 RU
Chassis Depth	10.77 inches w/o P/S 17.60 inches with P/S
Chassis Weight	14.08 lbs (6.67 kg) with two P/S & tray
Humidity (Operating and Storage)	0% to 95% non-condensing
Operating Temperature	-40C to +75C
Storage Temperature	-40C to +85C
Data rate (RJ-45)	10 or 100 Mbps (full or half duplex) 1 Gigabit per second (full duplex)
Data rate (SFP)	100/1000 Mbps (full duplex)
Maximum frame size	9216 bytes
Cable supported (RJ-45)	10BaseT: unshielded twisted-pair (UTP) 100BaseTX: unshielded twisted-pair (UTP), Category 5, EIA/TIA 568 or shielded twisted-pair (STP), Category 5, 100 ohm 1000BaseT: unshielded twisted-pair (UTP), Category 5e
Maximum cable distance (RJ-45)	100 meters

OmniSwitch 6855-U24

The OmniSwitch 6855-U24 is an edge/workgroup switch offering 24 SFP connectors, and two combo ports individually configurable to 10/100/1000Base-T.

The front panel of the OS6855-U24 chassis contains the following major components:

- System status and slot indicator LEDs
- (22) Unshared SFP connectors
- (2) Combo SFP connectors
- (2) Combo RJ-45 10/100/1000Base-T
- Console port (RJ-45)
- USB port (USB 2.0)

Note. USB port is not supported in this release.

Refer to the illustration below for more front panel information. For detailed LED descriptions, refer to [page 2-16](#). For information on the chassis rear panel, refer to [page 2-18](#).

Status LEDs

For information on the OS6855-U24's status LEDs, refer to [page 2-16](#).

1000Mbps SFP

The OS6855-U24 provides 22 non-combo SFP connectors (1–22) and 2 combo SFP connectors (24–24) for supported SFP transceivers.

USB Port

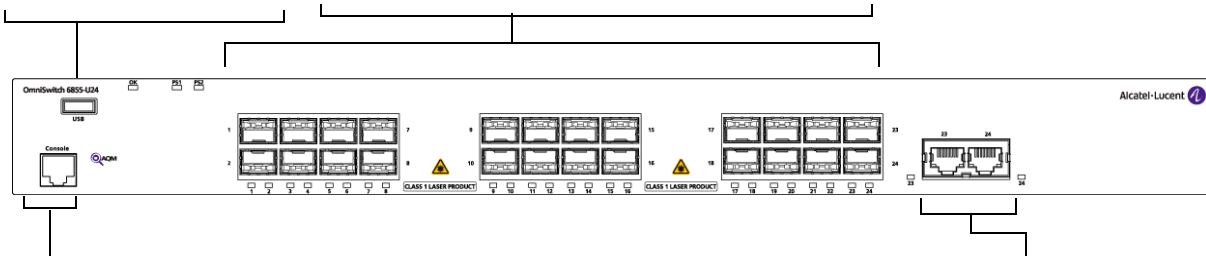

Console Port

The OS6855-U24 front panel provides one RJ-45 port for console connections. Console connections are used by network administrators for switch management. This female RJ-45 connector provides a DTE console connection.

Combo RJ-45 10/100/1000

The OS6855-U24 provides two combo 10/100/1000BaseT.

By default, when an SFP is installed in a combo port, it takes over the port number of the corresponding RJ-45 Ethernet port. In other words, if an SFP is installed in the slot labeled 24, Ethernet port 24 would no longer be available and cannot be used for 10/100/1000 traffic. This default setting is referred to as “preferred fiber.” Refer to “Configuring Ethernet” in the *Network Configuration Guide* for detailed information, including steps for configuring combo port settings.

OmniSwitch 6855-U24 Front Panel

OS6855-U24 Specifications	
Total unshared SFP connectors per switch (1–22)	22
Total shared SFP connectors per switch (23–24)	2
Total combo 10/100/1000Base-T per switch (23–24)	2
Flash memory size	128 MB
RAM memory size	256 MB SDRAM
Chassis Width	17.25 inches
Chassis Height	1.73 inches
Chassis Height (rack units)	1 RU
Chassis Depth	10.77 inches w/o P/S 17.60 inches with P/S
Chassis Weight	14.08 lbs (6.67 kg) with two P/S & tray
Humidity (Operating and Storage)	0% to 95% non-condensing
Operating Temperature	-40C to +75C
Storage Temperature	-40C to +85C
Data rate (RJ-45)	10 or 100 Mbps (full or half duplex) 1 Gigabit per second (full duplex)
Data rate (SFP)	100/1000 Mbps (full duplex)
Maximum frame size	9216 Bytes
Cable supported (RJ-45)	10BaseT: unshielded twisted-pair (UTP) 100BaseTX: unshielded twisted-pair (UTP), Category 5, EIA/TIA 568 or shielded twisted-pair (STP), Category 5, 100 ohm 1000BaseT: unshielded twisted-pair (UTP), Category 5e
Maximum cable distance (RJ-45)	100 meters

OmniSwitch 6855-14

The OmniSwitch 6855-C14 is an edge/workgroup switch offering 12 10/100/1000 Base-T, and two SFP connectors. Additionally, the first four ports support PoE.

The front panel of the OS6855-14 chassis contains the following major components:

- System status and slot indicator LEDs
- (12) Unshared 10/100/1000Base-T with PoE support on the first four ports
- (2) SFP connectors
- Console port (RJ-45)
- USB port (USB 2.0)

Note. USB port is not supported in this release.

Refer to the illustration below for more front panel information. For detailed LED descriptions, refer to [page 2-16](#). For information on the chassis rear panel, refer to [page 2-18](#).

Console Port

The OS6855-14 front panel provides one RJ-45 port for console connections. Console connections are used by network administrators for switch management. This female RJ-45 connector provides a DTE console connection.

Status LEDs

For information on the *OS6855-14*'s status LEDs, refer to [page 2-16](#).

SFP

The *OS6855-14* provides two SFP connectors for supported SFP transceivers.

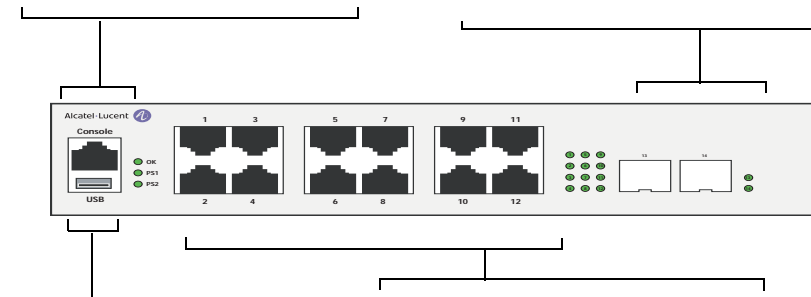

USB Port

10/100/1000Mbps

The OS6855-14 provides 12 fixed 10/100/1000BaseT non-combo (1–12). These are auto-sensing and auto-MDIX and use RJ-45 connectors. Additionally, the first four ports support PoE.

OmniSwitch 6855-14 Front Panel

OS6855-14 Specifications

Total unshared 10/100/000Base-T per switch (1–12)	12
Total 802.3af PoE ports per switch (1–4)	4
Total shared SFP connectors per switch (13–14)	2
Flash memory size	128 MB
RAM memory size	256 MB SDRAM
Chassis Width	8.5 inches
Chassis Height	1.73 inches
Chassis Height (rack units)	1 RU
Chassis Depth	10.25 inches w/o P/S 17.50 inches with P/S
Weight	9.13 lbs (4.15kg) with two P/S & tray
Humidity (Operating and Storage)	0% to 95% non-condensing
Operating Temperature	-40C to +70C
Storage Temperature	-40C to +85C
Data rate (RJ-45)	10 or 100 Mbps (full or half duplex) 1 Gigabit per second (full duplex)
Data rate (SFP)	100/1000 Mbps (full duplex)
Maximum frame size	9216 bytes
Cable supported (RJ-45)	10BaseT: unshielded twisted-pair (UTP) 100BaseTX: unshielded twisted-pair (UTP), Category 5, EIA/TIA 568 or shielded twisted-pair (STP), Category 5, 100 ohm 1000BaseT: unshielded twisted-pair (UTP), Category 5e
Maximum cable distance (RJ-45)	100 meters

OmniSwitch 6855-U10

The OmniSwitch 6855-U10 is an edge/workgroup switch offering 8 SFP connectors, and two ports individually configurable to 10/100/1000Base-T.

The front panel of the OS6855-U10 chassis contains the following major components:

- System status and slot indicator LEDs
- (8) Unshared SFP connectors
- (2) 10/100/1000Base-T
- Console port (RJ-45)
- USB port (USB 2.0)

Note. USB port is not supported in this release.

Refer to the illustration below for more front panel information. For detailed LED descriptions, refer to [page 2-16](#). For information on the chassis rear panel, refer to [page 2-18](#).

Console Port

The OS6855-U10 front panel provides one RJ-45 port for console connections. Console connections are used by network administrators for switch management. This female RJ-45 connector provides a DTE console connection.

Status LEDs

For information on the OS6855-U10's status LEDs, refer to [page 2-16](#).

SFP

The OS6855-U10 provides 8 SFP connectors (1–8) for supported SFP transceivers.

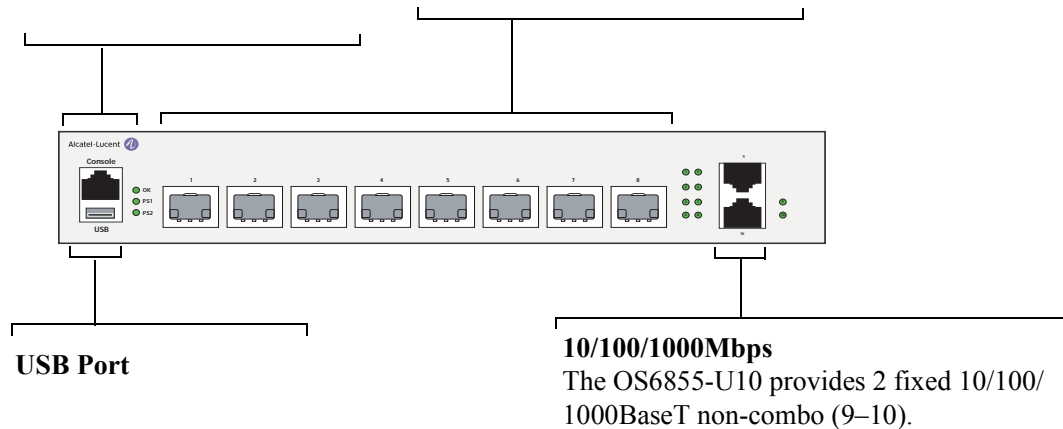

OmniSwitch 6855-U10 Front Panel

OS6855-U10 Specifications	
Total unshared SFP connectors per switch (1–8)	8
Total unshared 10/100/1000Base-T per switch (9–10)	2
Flash memory size	128 MB
RAM memory size	256 MB SDRAM
Chassis Width	8.5 inches
Chassis Height	1.73 inches
Chassis Height (rack units)	1 RU
Chassis Depth	10.25 inches w/o P/S 17.50 inches with P/S
Weight	9.13 lbs (4.15kg) with two P/S & tray
Humidity (Operating and Storage)	0% to 95% non-condensing
Operating Temperature	-40C to +70C
Storage Temperature	-40C to +85C
Data rate (RJ-45)	10 or 100 Mbps (full or half duplex) 1 Gigabit per second (full duplex)
Data rate (SFP)	100/1000 Mbps (full duplex)
Maximum frame size	9216
Cable supported (RJ-45)	10BaseT: unshielded twisted-pair (UTP) 100BaseTX: unshielded twisted-pair (UTP), Category 5, EIA/TIA 568 or shielded twisted-pair (STP), Category 5, 100 ohm 1000BaseT: unshielded twisted-pair (UTP), Category 5e
Maximum cable distance (RJ-45)	100 meters

Status LEDs

LEDs provide visual status information. These “status lights” are used to indicate conditions, such as hardware and software status, primary role status, power supply status, fan and temperature errors, data speed, link integrity, and activity. Refer to the diagram below for detailed information on LED states.

OK. Solid green when the switch has passed hardware diagnostic tests and the system software is operational. Solid amber when a hardware or system software failure occurs. Blinks green during normal diagnostics.

PS1. Solid green when the primary (i.e., factory-installed) power supply status is OK and the power supply is operating normally. Solid amber in the event of a power supply failure.

PS2. Solid green when an

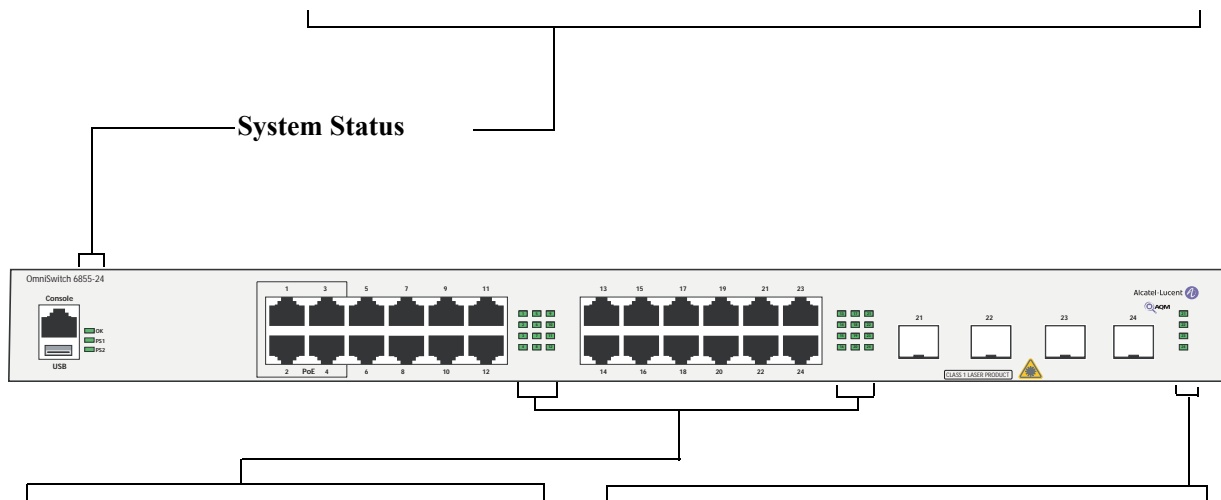

Ethernet Port LEDs

10/100/1000 Ethernet port have one built-in status LED. This LED indicate the data speed and link/activity either PoE or non-PoE status for each corresponding Ethernet port. 1000 Mbps SFP have a single LED for activity. See [page 2-16](#) for more information.

Combo Port Status LEDs

Displays solid green when an SFP is installed in the corresponding port and a link state exists; blinks green when transmitting or receiving traffic; off when no activity is present or no SFP is installed.

By default, when an SFP is installed, it takes over the port number of the corresponding RJ-45 Ethernet port. If an SFP is installed in the slot labeled 23, Ethernet port 23 is no longer available and cannot be used for 10/100/1000 traffic. For detailed information on changing combo port settings, see “Configuring Ethernet” in the *Network*

LED	State	Description
OK	Solid Green	Normal Operation.
	Solid Amber	Operating Temperature Exceeded.
PS1	Solid Green	PS1 Normal Operation.
	Amber	PS1 Present and Bad (24-port models only)
	Off	PS1 Not Present or Bad.
PS2	Solid Green	PS2 Normal Operation.
	Amber	PS2 Present and Bad (24-port models only)
	Off	PS2 Not Present or Bad.
10/100/1000 Ports	Solid Green	Valid Link
	Blinking Green	Transmitting or receiving packets in a link up state for non-PoE .
	Solid Amber	Valid PoE Link.
	Blinking Amber	Transmitting or receiving packets in a link up state for PoE .
	Off	No Link Detected.
SFP Ports	Solid Green	Valid Link.
	Blinking Green	Transmitting or receiving packets in a link up state .
	Off	No Link Detected.

Rear Panel

OS6855-24/OS6855-U24

The rear panel of OS6855-24/OS6855-U24 switches contains the following major components:

- Two DB-25 connectors provided for primary and redundant power supplies.
- Grounding block for type LCD8-10A-L grounding lug

Note. The figure shows a pre-production version of the chassis without product, safety, and compliance information labels. All production versions of the chassis have these labels.



Power Supply Con-
nectors

Two DB-25 connectors for an
external OS6855-24/OS6855-U24

OS6855-24/OS6855-U24 Rear Panel

OS6855-14

The rear panel of OS6855-14 switch contains the following major components:

- Two 3-pin connectors provided for primary and redundant system power supplies
- Two 4-pin connectors provided for primary and redundant PoE power supplies
- Grounding block for type LCD8-10A-L grounding lug

Note. The figure shows a pre-production version of the chassis without product, safety, and compliance information labels. All production versions of the chassis have these labels.

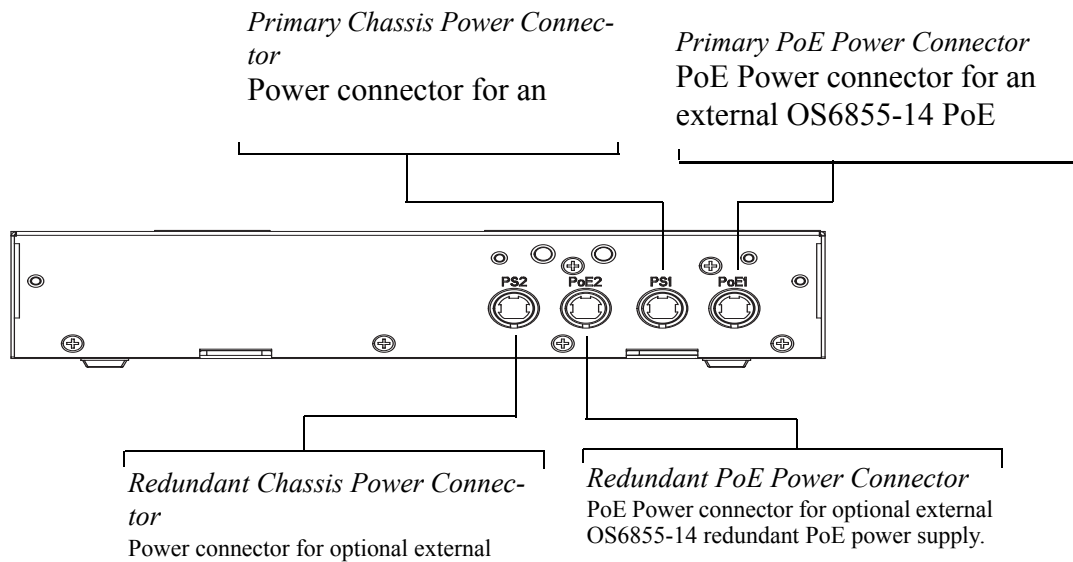

OS6855-14 Rear Panel

OS6855-U10

The rear panel of OS6855-U10 switch contains the following major components:

- Two multi-contact connectors provided for primary and redundant power supplies.
- Grounding block for type LCD8-10A-L grounding lug

Note. The figure shows a pre-production version of the chassis without product, safety, and compliance information labels. All production versions of the chassis have these labels.

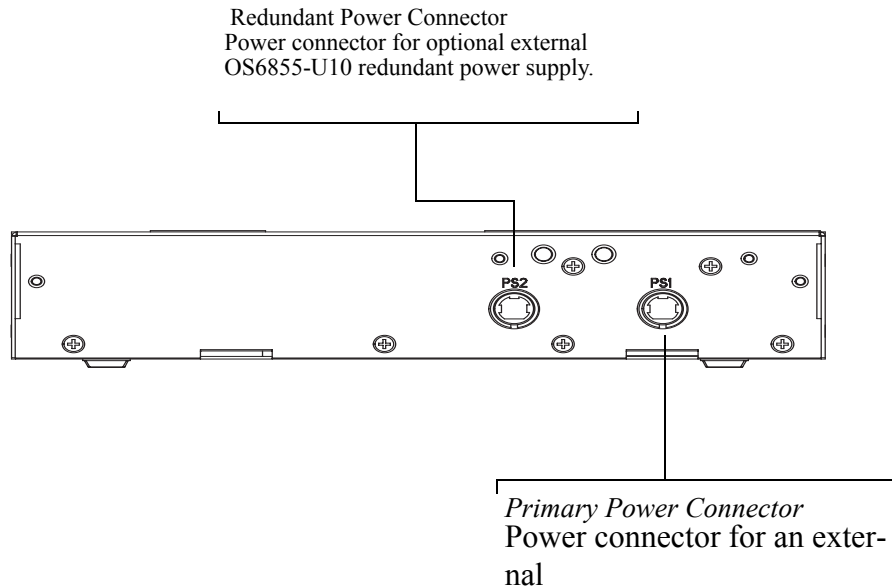

OS6855-U10 Rear Panel

OS6855-24/U24 Power Supplies

- PS-126I80AC Power Supply (see [“PS-126I80AC Power Supply”](#) on page 2-22)
- PS-360I160AC-P PoE Power Supply (see [“PS-360I160AC-P Power Supply”](#) on page 2-23)
- PS-120I80DC48 - 48V DC Power Supply (see [“PS-120I80DC48 Power Supply”](#) on page 2-25)
- PS-100I80DC24 - 24V DC Power Supply (see [“PS-100I80DC24 Power Supply”](#) on page 2-26)

PS-126I80AC Power Supply

The PS-126I80AC Power Supply provides full system power for OmniSwitch 6855 Series switches and can be installed as either a primary or backup system power supply.

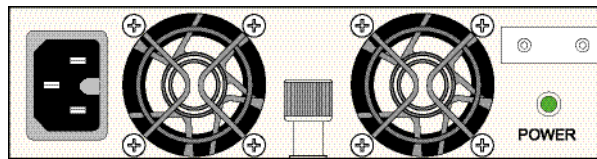
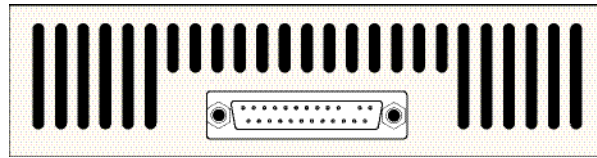

80W AC System Power Supply

P/S Component	Description
Model	PS-126I80AC
Provides System Power For	OS6855-24 and OS6855-U24
Input Voltage Range	90 to 265 VAC
Rated Frequency	47 to 63 Hz
Inrush Current	< 30A
Maximum Output Power	80 W
Output Voltage	12.0 VDC (typical)
Output Current	6.7 A (maximum)

PS-360I160AC-P Power Supply

The PS-360I160AC-P Power Supply provides full system and Power over Ethernet (PoE) for the OmniSwitch 6855-24 and can be installed as either a primary or backup system and PoE power supply.

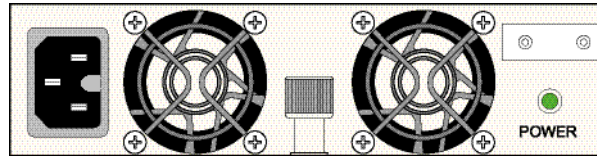
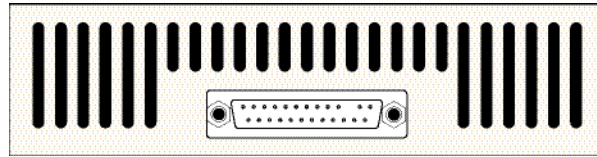

160W, AC PoE/System Power Supply

P/S Component	Description
Model	PS-360I160AC-P
Provides System and PoE Power For	OS6855-24
Input Voltage Range	90 to 265 VAC
Rated Frequency	47 to 63 Hz
Inrush Current	< 30 A
Maximum PoE Output Power	80 W
Maximum System Output Power	80 W
PoE Output Voltage	-54.0 VDC, +/-50mV at 40W (50% load) load set point
PoE Output Current	1.5 A (maximum)
Sytem Output Voltage	12.0 VDC (typical)
Sytem Output Current	6.7 A (maximum)

PS-120I80DC48 Power Supply

The PS-120I80DC48 DC Power Supply provides full system power for OmniSwitch 6855 Series switches and can be installed as either the primary or backup system power supply.

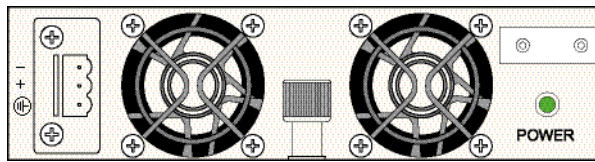
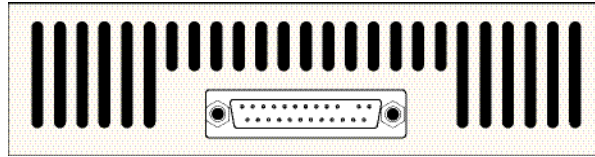

80W, -48VDC System Power Supply

P/S Component	Description
Model	PS-120I80DC48
Provides System Power For	OS6855-24 and OS6855-U24
Input Voltage Range	-36 to -72 VDC (-48 VDC Nominal Input)
Inrush Current	< 30A
Maximum Output Power	80 W
Output Voltage	12.0 VDC (typical)
Output Current	6.7 A (maximum)

PS-100I80DC24 Power Supply

The PS-100I80DC24 Power Supply provides full system power for OmniSwitch 6855 Series switches and can be installed as either the primary or backup system power supply.

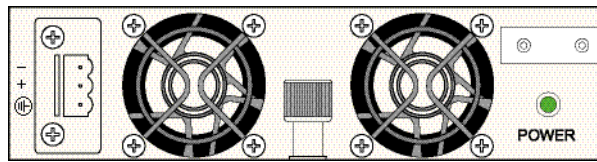
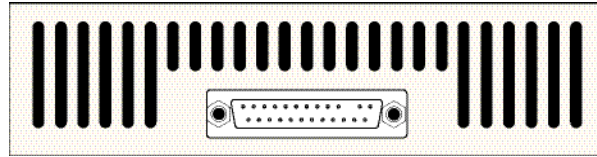

80W, 24VDC System Power Supply

P/S Component	Description
Model	PS-100I80DC24
Provides System Power For	OS6855-24 and OS6855-U24
Input Voltage Range	20 to 36 VDC (24V Nominal Input)
Inrush Current	< 30 A
Maximum Output Power	80 W
Output Voltage	12.0 VDC (typical)
Output Current	6.7 A (maximum)

OS6855-14/U10 Power Supplies

- PS-I40AC - System Power Brick (see [“PS-I40AC Power Brick”](#) on page 2-29)
- PS-I66AC-P - PoE Power Brick (see [“PS-I66AC-P PoE Power Brick”](#) on page 2-30)
- PS-I40DC2448 - DC Power Brick (see [“PS-I40DC2448 Power Brick”](#) on page 2-31)
- PS-I40DC2448E - DC Power Brick (see [“PS-I40DC2448E Power Brick”](#) on page 2-32)
- PS-75I42DC48-P - DC Power Brick (see [“PS-75I42DC48-P PoE Power Brick”](#) on page 2-33)

PS-I40AC Power Brick

The PS-I40AC Power Brick provides full system power for the OmniSwitch 6855 Series switches and can be installed as either the primary or backup system power supply.

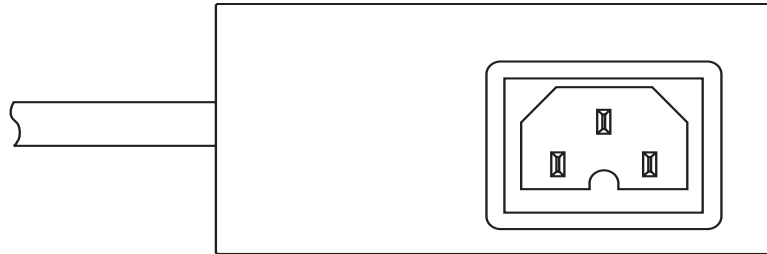

40W, AC System Power Brick

P/S Component	Description
Model	PS-I40AC
Provides System Power For	OS6855-14 and OS6855-U10
Input Voltage Range	100-120/200-240 VAC
Rated Frequency	47 to 63 Hz
Inrush Current	< 30A
Maximum Output Power	40 W
Output Voltage	12.0 VDC, +/-100mV at 40W load set point (+/-1%)
Output Current	0.0 A (minimum), 3.4 A (maximum)

PS-I66AC-P PoE Power Brick

The PS-I66AC-P PoE Power Brick provides Power over Ethernet for the OmniSwitch 6855-14 and can be installed as either the primary or backup PoE power supply.

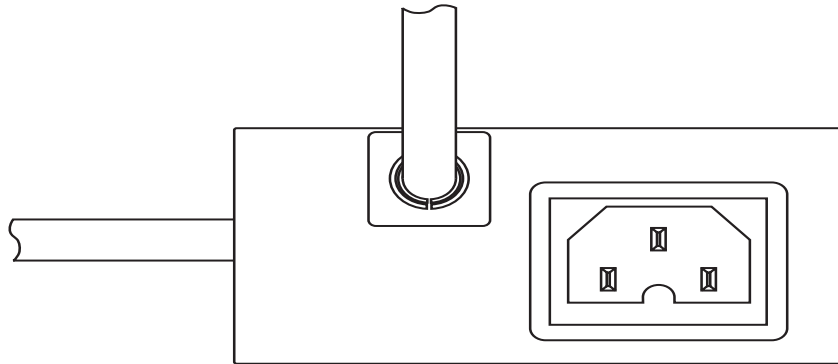

66W, AC PoE Power Brick

P/S Component	Description
Model	PS-I66AC-P
Provides PoE Power For	OS6855-14
Input Voltage Range	100-120/200-240 VAC
Rated Frequency	47 to 63 Hz
Inrush Current	< 30A
Maximum Output Power	66 W
Output Voltage	-54.0 VDC, +/-1V at 33W (50% load) load set point.
Output Current	0.0 A (minimum), 1.5 A (maximum)

PS-I40DC2448 Power Brick

The PS-I40DC2448 DC Power Brick provides full system power for the OmniSwitch 6855 Series switches and can be installed as either the primary or backup system power supply.



40W, 24/-48VDC System Power Brick

P/S Component	Description
Model	PS-I40DC2448
Provides System Power For	OS6855-14 and OS6855-U10
Input Voltage Range	-24 to -48 VDC
Inrush Current	< 30A
Maximum Output Power	40 W
Output Voltage	12.0 VDC, +/-100mV at 40W load set point
Output Current	0.0 A (minimum), 3.4 A (maximum)

Note. The polarity of this non-PoE DC power supply is opposite of the PoE DC power supply. See [“PS-75142DC48-P PoE Power Brick”](#) on page 2-33.

PS-I40DC2448E Power Brick

The PS-I40DC2448E DC Power Brick provides full system power for the OmniSwitch 6855 Series switches and can be installed as either the primary or backup system power supply.



40W, 24/-48VDC System Power Brick

P/S Component	Description
Model	PS-I40DC2448E
Provides System Power For	OS6855-14 and OS6855-U10
Input Voltage Range	-20 to -60 VDC
Inrush Current	< 30A
Maximum Output Power	40 W
Output Voltage	12.0 VDC, +/-100mV at 40W load set point
Output Current	0.0 A (minimum), 3.4 A (maximum)

Note. The polarity of this non-PoE DC power supply is opposite of the PoE DC power supply. See [“PS-75142DC48-P PoE Power Brick”](#) on page 2-33.

PS-75I42DC48-P PoE Power Brick

The PS-75I42DC48-P DC PoE Power Brick provides Power over Ethernet for the OmniSwitch 6855-14 and can be installed as either the primary or backup PoE power supply.



75W, -54.5VDC PoE Power Brick

P/S Component	Description
Model	PS-75I42DC48-P
Provides System Power For	OS6855-14
Input Voltage Range	-40 to -60 VDC
Inrush Current	ETSI 300 132-2 Compliant
Maximum Output Power	75 W
Output Voltage	-54 VDC, +/- 2%
Output Current	0.0 A (minimum), 1.2 A (maximum)

Note. The polarity of this PoE DC power supply is opposite of the non-PoE DC power supplies. See [“PS-I40DC2448 Power Brick”](#) on page 2-31 and [“PS-I40DC2448E Power Brick”](#) on page 2-32.

UL Recognized Power Supply Table

POWER SUPPLIES:

Only the following UL Recognized Component Power Supplies may be used for OS6855-U10, OS6855-14, OS6855-24 & OS6855-U24 bearing the UL Listing Mark -

Model OS6855	Supply Voltage	UL Recognized Component (QQGQ2) Power Supplies	
	AC, DC, PoE	Recognized Company Name	Model Numbers
-U10, -14	AC	Advanced Power Solutions (APS)	PS-I40AC
	AC	Autec Power Systems Inc.	PS-I40AC
	DC	Advanced Power Solutions (APS)	PS-I40DC2448E
	DC	Autec Power Systems Inc.	PS-I40DC2448E
-14	PoE	Advanced Power Solutions (APS)	PS-I66AC-P
	PoE	Autec Power Systems Inc.	PS-I66AC-P
-24, -U24	AC	Universal Micro Electronics Co. Ltd	PS-126I80AC
	DC	Hitron Electronics Corporation	PS-100I80DC24
	DC	Hitron Electronics Corporation	PS-100I80DC48
-24	PoE	3Y Power Technology Inc.	PS-360I160AC-P

Power Supply Shelf

OS6855-24/U24

Alcatel-Lucent requires the use of the power supply shelf when connecting power supplies. The shelf can be attached directly to the back of the chassis or rack mounted.

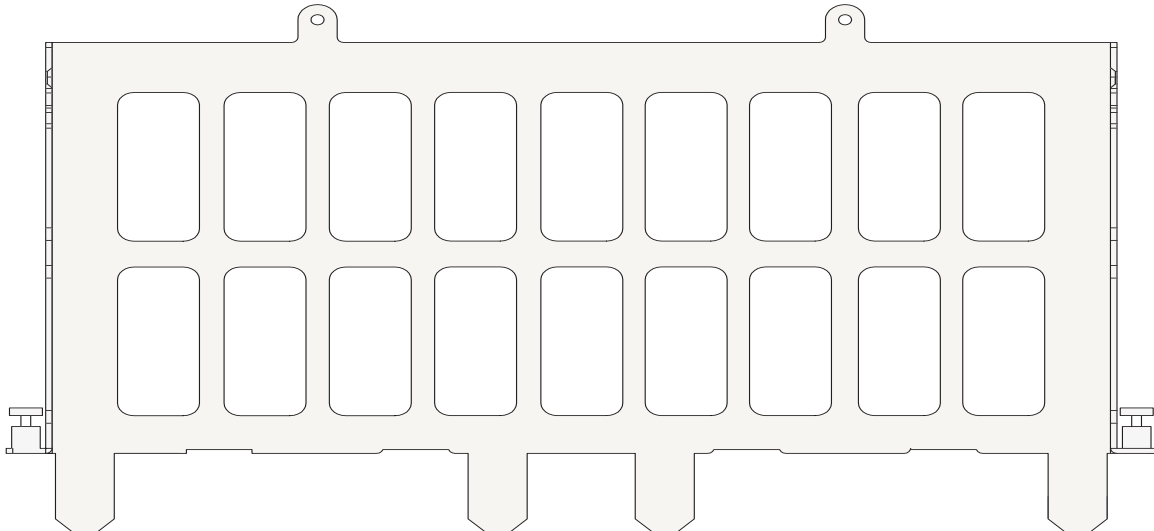

OS6855-24/U24 Power Supply Shelf

OS6855-14/U10

Alcatel-Lucent requires the use of the power supply shelf when connecting power supplies. The shelf can be attached directly to the back or side of the chassis or rack mounted.

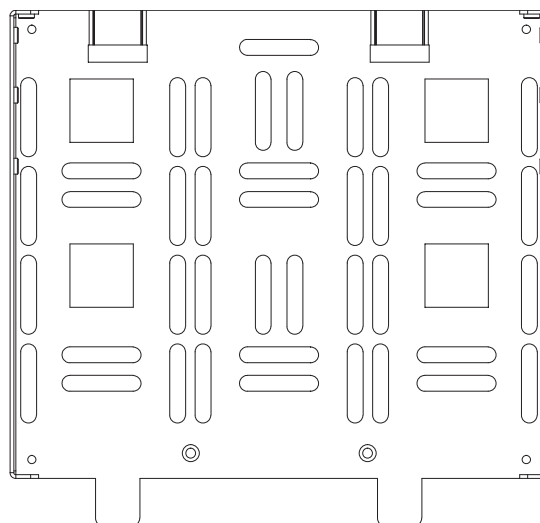

OS6855-14/U10 Power Supply Shelf

AC Power Cords

Since the power cord is the switch's only disconnect device, it should be plugged into an easily accessible outlet. In the event that your power cord is lost or damaged, refer to the specifications below.

Specifications

The power cord included with this product contains three (3) insulated #18AWG stranded copper wires and is rated between 85-265 VAC (region dependent), 10 amps with a nominal length of 2 meters. The female end terminates in an IEC-60320-C15 attachment plug and the male end termination varies dependent upon region, as listed below.

European cords must be Harmonized (HAR) type. Refer to the information below for power plug types by region:

Power Cord Types	User Side Connectors
North America	NEMA 5-15-P
United Kingdom / Ireland	BS 1363 UK
Europe	CEE 7/7
Japan	JIS 8303
Australia	AS 3112
India	BS 546
Italy	CIE 23-16
Switzerland / Liechtenstein	SEV 1011
Denmark / Greenland	SRAF 1962 / DB 16/87
Argentina	A-10

Power Cord Notch

Note the power cord notch designed to match with the



IEC-60320-C15

Supplied 6855 Power Cord Specifications

DC Power Supply Considerations

In addition to the installation steps described in “Connecting a Power Supply Directly to the Chassis” on page 3-5 and “Rack Mounting the Power Supply Tray” on page 3-6 DC power supplies have the following additional considerations:

- Connect to a -48V reliably grounded DC SELV source if using either a PS-120I80DC48 or PS-I40DC2448 power supply.
- Connect to a 24V reliably grounded DC SELV source if using a PS-100I80DC24 or PS-I40DC2448 power supply.
- Use common DC return connections for the DC power supplies. The DC return terminal conductor should be connected to the equipment frame.
- The Branch Circuit Overcurrent Protection must be rated a Maximum of 15A.
- Use 12AWG solid conductors only.
- A readily accessible disconnect device that is suitably approved and rated shall be incorporated in the field wiring.

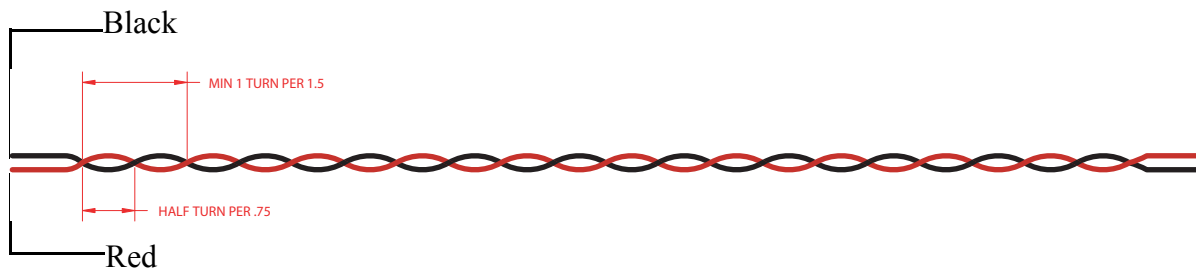

Twisted pair wire (red and black) for a DC power supply

Note. Refer to the wiring diagram for information on connecting the DC power supply to a DC power source.

Connecting a DC Power Source

The DC power supply on your switch contains a power connector with three (3) square slots for connecting the positive, negative, and ground wires from a DC power source.

DC Power Connectors

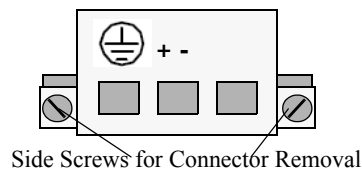

OmniSwitch DC Power Supply Connector

A clamp inside each slot keeps the power wire tightly in place during operation.

The DC power supply has side screws that can be used to remove the connector if required.

Installing DC Power Source Wire Leads

These instructions describe how to connect your 3-wire DC power source to the power connector on your DC power supply. A small flat-tip screwdriver and a wire stripper are required for this procedure.

- 1** Prepare the three (3) wires—12 gauge—that will plug into the power supply. First make sure they are not plugged into the DC power source. Next, use a wire stripper to carefully strip between .24 and .30 inches (6-7.5 mm) off the end of each wire, removing the outer insulation to expose the copper core.
- 2** Open the clamp for the ground wire slot by inserting a small flat-tip screwdriver into the top of the appropriate circular hole. Loosen the screw so that the clamp for the ground wire opens.

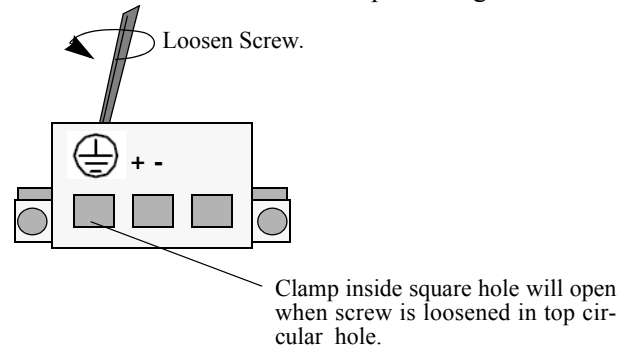

Opening Connector for Ground Wire

- 3** Insert the ground wire lead into the slot. The lead you insert *must* match the lead attached to the DC power source.

Warning. You must plug DC wire leads into the correct holes in the DC power connector. Use the labels above the DC power connector as a guide to positive, negative, and ground connections. If the wire leads are plugged into the wrong holes, the power supply will not work properly and damage to the unit may result.

Push the wire in far enough such that it reaches the back wall of the connector, about a half inch inside.

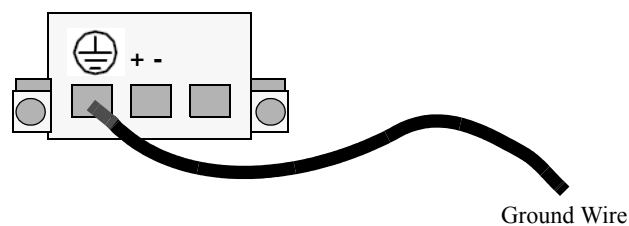

Attaching the Ground Wire

4 Tighten the clamp by tightening the screw above the slot into which you inserted the wire lead. The wire lead should be securely attached inside the connector. You should be able to pull on the wire and not dislodge it.

Warning. For both 24V and -48V input voltages, the positive (+) wire of the sourcing equipment, such as a battery or rectifier, must be connected to the positive (+) terminal of the OmniSwitch DC power supply and the negative (-) wire of the sourcing equipment must be connected to the negative (-) terminal of the OmniSwitch DC power supply. This rule always applies to both 24V, and -48V input voltages, regardless of the polarity signs shown on the power supply specification labels such as: -48V, +24V, or -24V."

5 Repeat Steps 2 through 4 for the remaining positive and negative wire leads.

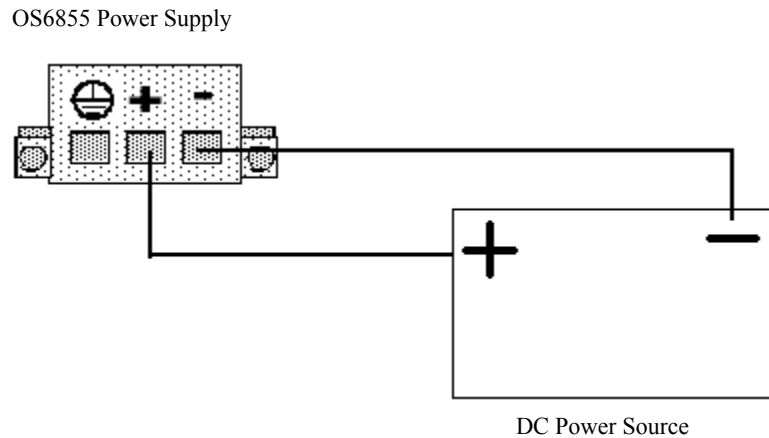

Correct Polarity Connections

Console Port

The console port, located on the chassis front panel, provides a console connection to the switch and is required when logging into the switch for the first time. By default, this RJ-45 connector provides a DTE console connection.

Serial Connection Default Settings

The factory default settings for the serial connection are as follows:

baud rate	9600
parity	none
data bits (word size)	8
stop bits	1
flow control	none

Port Pinouts

RJ-45 Console Port – Connector Pinout

Pin Number	Signals as DTE Console Port
1	NC
2	NC
3	RXD
4	Ground
5	Ground
6	TXD
7	NC
8	NC

10/100 Ethernet Port – RJ-45 Pinout (non-PoE)

Pin Number	Description
1	RX+
2	RX-
3	TX+
4	not used
5	not used
6	TX-
7	not used
8	not used

Gigabit Ethernet Port – RJ-45 Pinout

Pin Number	Description
1	BI_DB+
2	BI_DB-
3	BI_DA+
4	BI_DD+
5	BI_DD-
6	BI_DA-
7	BI_DC+
8	BI_DC-

10/100/1000 Mbps Power over Ethernet Port – RJ-45 Pinout

Pin Number	Description
1	RX+ (-VDC)
2	RX- (-VDC)
3	TX+ (+VDC)
4	
5	
6	TX- (+VDC)
7	
8	

Overtemp Condition

The OmniSwitch 6855 is designed to operate within a wider operating temperature range than normal network equipment as noted under the specifications section. However, in the event that the normal operating temperature of the switch is exceeded, the following will occur:

- Upon crossing the configured overtemperature threshold, a trap will be sent. (See the *OmniSwitch AOS Release 6 Network Configuration Guide* for information on configuring switch thresholds.

If the temperature continues to rise above the maximum operating temperature, the following will occur:

- OK LED will display solid Amber.
- The switch will automatically shutdown
- Once the temperature drops to an acceptable operating level, the switch will automatically restart.

Check the following if an overtemp condition exists:

- Verify that the switch is installed properly in an environment that adheres to the installation instructions in the following chapters.
- Verify proper airflow to the chassis.

3 Mounting OS6855-24 and OS6855-U24

Note. Never obstruct the air intake or exhaust vents located on the chassis. Obstructing these vents can cause switch failure. Always follow the recommended clearance values.

General Mounting Recommendations

Be sure that your switch is placed in a well-ventilated, static-free environment. Always allow adequate clearance at the front, rear, top, and sides of the switch. Refer the the table below for detailed information on recommended chassis clearances.

Recommended Clearances

Always allow adequate clearance at the front, rear, top, and sides of the switch. The following table shows the recommended minimum clearances for adequate chassis airflow and access to cabling and components at the front and rear of the chassis.

Location	OS6855-24	OS6855-U24
Top	No minimum clearance required. However, be sure that the top of the chassis is not in direct contact with any equipment above.	0.875 inches (1/2 RU)
Bottom	No minimum clearance required. However, be sure that the bottom of the chassis is not in direct contact with any equipment below.	No minimum clearance required. However, be sure that the bottom of the chassis is not in direct contact with any equipment below.
Sides	2 inches	2 inches
Rear	6 inches (see note below)	6 inches (see note below)
Front	6 inches (see note below)	6 inches (see note below)

Note. Clearance recommendations at the front and rear of chassis are for access to cabling and components only and are not intended as a specific airflow requirement.

Elevated Operating Ambient Temperatures

If installed in a closed or multi-unit rack assembly, the operating ambient temperature of the rack environment may be greater than room ambient. Therefore, consideration should be given to installing the equipment in an environment compatible with the maximum ambient temperature (T_{ma}) specified by the manufacturer.

Reduced Air Flow

Installation of the equipment in a rack should be such that the amount of air flow required for safe operation of the equipment is not compromised.

Mechanical Loading

Mounting of the equipment in the rack should be such that a hazardous condition is not achieved due to uneven mechanical loading.

Circuit Overloading

Consideration should be given to the connection of the equipment to the supply circuit and the effect that overloading of the circuit might have on overcurrent protection and supply wiring. Appropriate consideration of equipment nameplate ratings should be used when addressing this concern.

Reliable Earthing

Reliable earthing of rack-mount equipment should be maintained. Particular attention should be given to supply connections other than direct connections to the branch circuit (e.g. use of power strips).

Airflow Recommendations

Air flow for the OS6855-24 switch differs slightly from the air flow for OS6855-U24 switches. The OS6855-24 draws air from intake vents located in the front and right chassis panels and exhausts air via fan vents located in the left chassis panel. The OS6855-24 draws air from an intake vent located in the top panel and exhausts air via louvered vents located at the top-rear of the switch.

For each switch, air is directed horizontally through the chassis, where it passes over the circuit board and provides necessary cooling for internal components. Refer to the diagrams below for more information.

1. Air Intake. The chassis fans pull air from the main air intake vents located in the left-hand panel of the chassis.

Air is also pulled in through an intake vent in the chassis front panel.

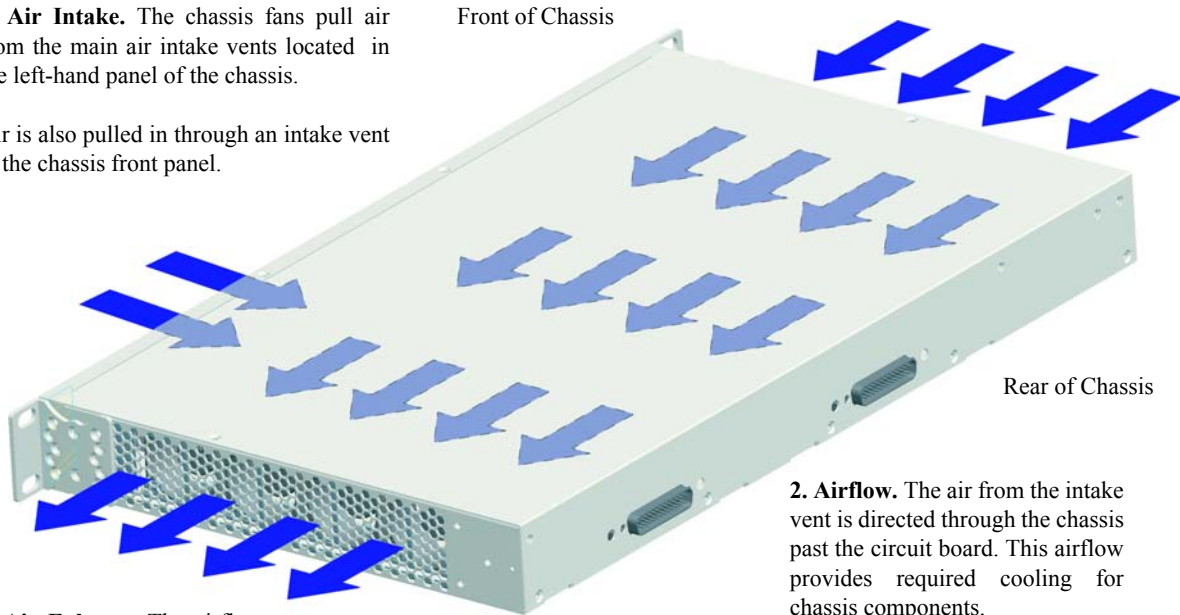

3. Air Exhaust. The airflow is exhausted through the fan exhaust vents at the right-hand side of the chassis.

2. Airflow. The air from the intake vent is directed through the chassis past the circuit board. This airflow provides required cooling for chassis components.

Chassis Airflow for OS6855-U24

1. Air Intake. The chassis fans pull air from the main air intake vent located at the top-front of the chassis.

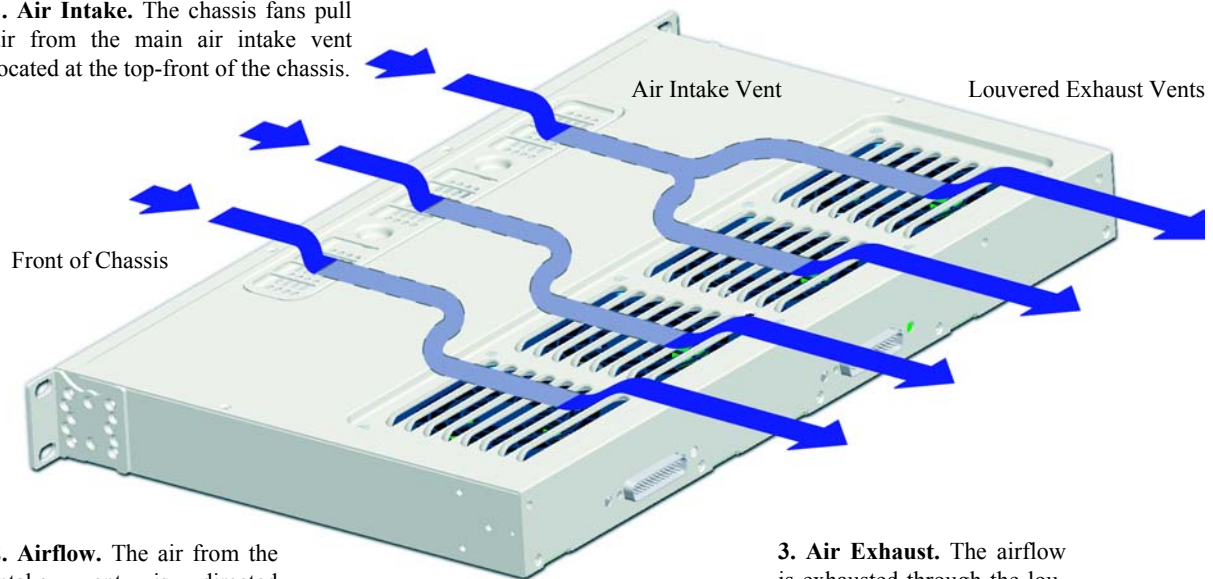

2. Airflow. The air from the intake vent is directed through the chassis past the circuit board. This airflow provides required cooling for chassis components.

3. Air Exhaust. The airflow is exhausted through the louvered fan exhaust vents at the top-rear of the chassis.

Installing Power Supplies

OmniSwitch 6855 Series power supply can be installed in the following ways:

- As a primary or backup supply directly connected to the back of an OmniSwitch 6855 Series chassis. See [“Connecting a Power Supply Directly to the Chassis” on page 3-5](#) for more information.
- As a primary or backup supply connected with a cable. See [“Rack Mounting the Power Supply Tray” on page 3-6](#) for more information.

DC power supplies require additional installation steps. See [“DC Power Supply Considerations” on page 2-37](#) for more information.

Anti-Static Warning. Before handling any components, free yourself of static by wearing a grounding strap, or by grounding yourself properly. Static discharge can damage the switch and the backup power supply.

Connecting a Power Supply Directly to the Chassis

Follow the steps below to connect a power supply directly (i.e., without a cable) to the back of an OmniSwitch 6855 Series chassis:

- 1 Place the chassis and power supply tray on a smooth, clean, and dry surface.
- 2 Carefully slide the power supply tray so that it is flush against the back of the chassis.

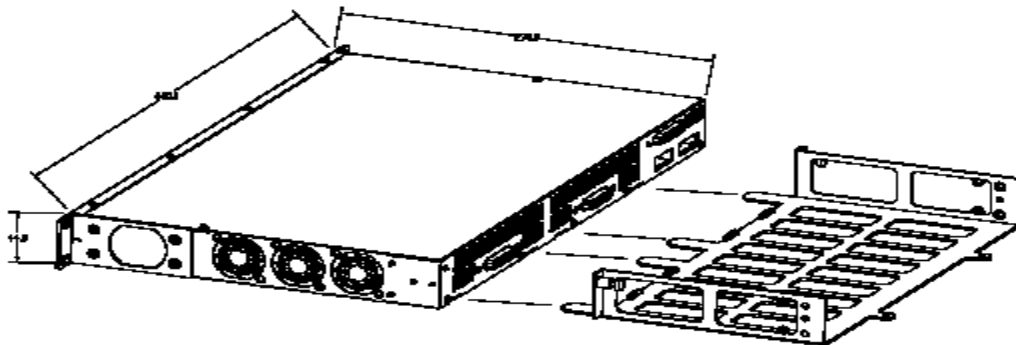

- 3 Tighten the two captive screws located on the left and right sides of the power supply tray.

- 4 Carefully slide the power supply against the back of the chassis until the power connector securely connects.

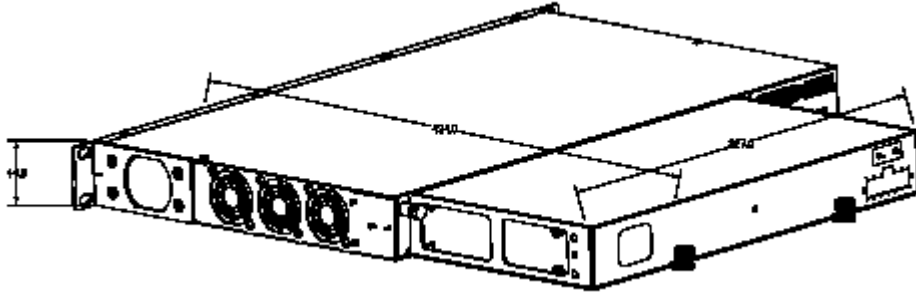

- 5 Tighten the captive screw for each power supply located at back of the power supply to the power supply tray.

Rack Mounting the Power Supply Tray

The following section describes how to rack-mount a power supply tray and connect the power supply with a cable.

- 1 Align the threaded holes in the provided rack-mount flanges with the holes in the power supply tray. These holes are located on the left and right sides of the tray.
- 2 Attach the flanges to the tray using the provided Phillips-head screws. The screws slide through the non-threaded holes from the inside of the power supply tray and are then attached to the mounting brackets using the threaded holes. Be sure to tighten each of the screws firmly using a Phillips screwdriver.

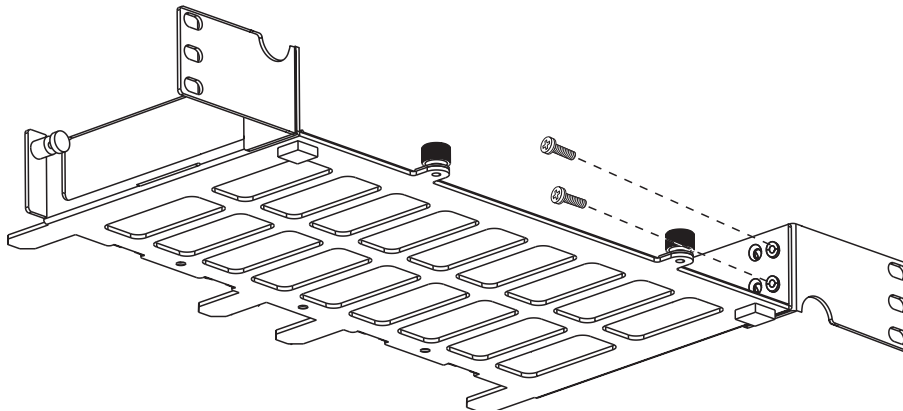

Attaching a Rack-Mount Flange

- 3** Carefully slide the power supply on to the power supply tray and secure the power supply to the tray using the captive screws.

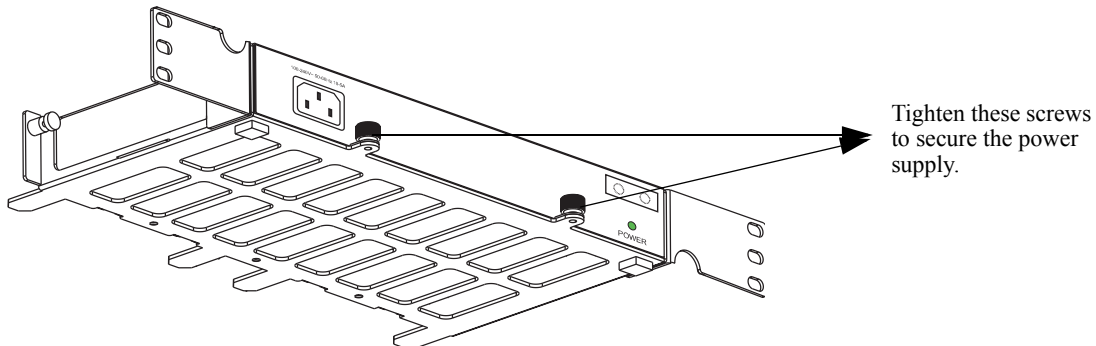

Attaching a Power Supply to the Power Supply Tray

Note. Two power supply types can be attached to a power supply tray.

- 4** After the rack-mount flanges and the power supply are secured to the tray, mark the holes on the rack where the tray is to be installed.
- 5** Lift and position the tray until the rack-mount flanges are flush with the rack post.
- 6** Align the holes in the flanges with the rack holes that were marked earlier.
- 7** Once the holes are aligned, insert a rack mount screw (not provided) through the *bottom hole of each flange*. Tighten all screws until they are secure.

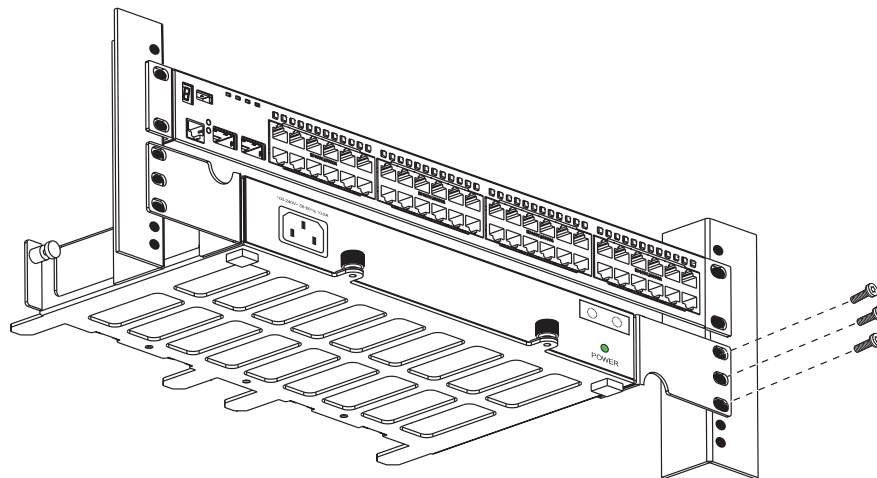

Attaching the Power Supply Tray to the Rack

Note. Be sure to install the screws in the *bottom hole* of each flange, as shown, before proceeding.

- 8** Once the screws at the bottom of each flange are secure, install the remaining rack mount screws. Be sure that all screws are securely tightened.

Connecting the Power Supply Cable

Follow the steps below to connect a power supply with a cable:

- 1 Be sure the chassis (see [“Rack-Mounting the Chassis” on page 3-12](#)) and power supply tray are securely fastened to the rack.
- 2 Connect the proper end of the supplied power supply cable to the appropriately labeled primary or backup connector on the switch and tighten securely.
- 3 Connect the other end of the power supply cable to the power supply and securely tighten.
- 4 Connect the power cord to the power supply.

Note. The diagram below shows an example of mounting the switch and power supplies in a 2U scenario. Depending on the switch model, power supplies, and rack mounting options the actual mounting options will vary.

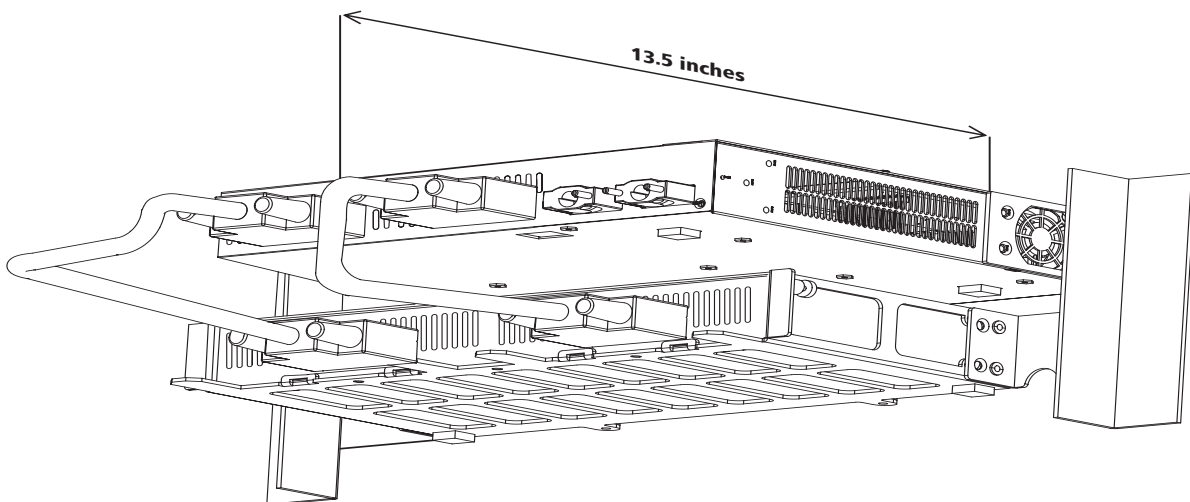

Redundant Power Supplies

Securing Power Supply Cord

The following section describes how to secure the power supply cord to the power supply using the included power supply cord retaining bracket.

- 1** If necessary, disconnect the AC power cord from the power supply.
- 2** Remove the screw directly above the AC power supply receptacle on the power supply and set aside, this screw will be used to secure the power supply cord retaining bracket.
- 3** Plug the AC power cord into the AC power supply receptacle on the power supply.
- 4** Slide the power cord retaining bracket's slot over the AC power cord.
- 5** Slide the bracket towards the chassis until the top hole in the bracket lines up with the screw hole in the power supply.
- 6** Secure the power cord retaining bracket to the power supply using the power supply screw removed in step 2 above.

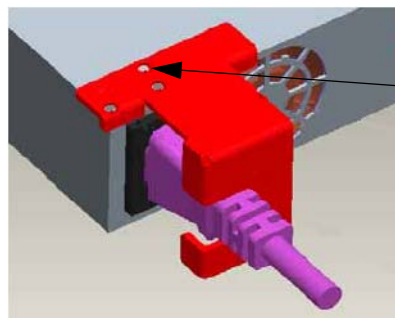

Use top hole to secure the power supply cord retaining bracket.

Power Cord Retaining Bracket

Hot-Swapping Power Supplies

OmniSwitch 6855 Series switches support hot-swapping of their power supplies. The following sections describe how to hot-swap a power supply either directly connected (i.e., without a cable) or rack-mounted power supply.

Warning: Before proceeding, ensure a redundant power supply is connected and operational.

Anti-Static Warning. Before handling any components, free yourself of static by wearing a grounding strap, or by grounding yourself properly. Static discharge can damage the switch and the backup power supply.

Hot-Swapping a Power Supply Directly Connected to the Chassis

- 1 Disconnect the power supply to be hot-swapped from its power source.
- 2 Loosen the captive screw of the power supply to be hot-swapped.
- 3 Carefully slide the power supply out of the power supply tray and set aside.

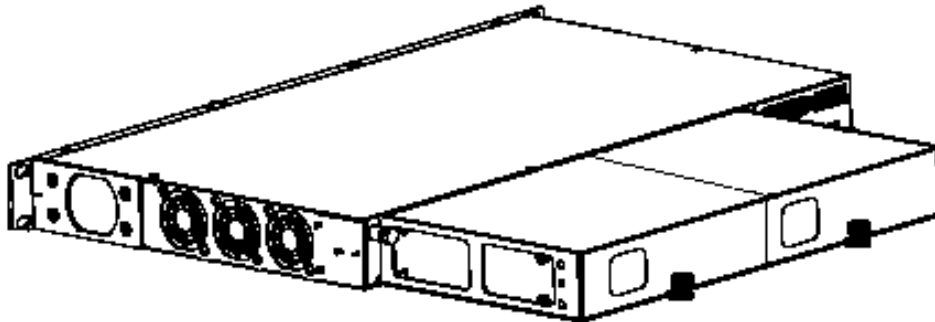

Directly Connected Power Supply

- 4 Carefully slide the new power supply onto the tray and against the back of the chassis until the power connector securely connects
- 5 Tighten the captive screw for the new power supply to the power supply tray.
- 6 Re-connect the power supply to its power source.

Hot-Swapping a Rack Mounted Power Supply

- 1** Disconnect the power supply to be hot-swapped from its power source.
- 2** Loosen the power supply cable of the power-supply to be hot-swapped and disconnect from power supply.
- 3** Loosen the captive screw of the power supply to be hot-swapped.
- 4** Carefully slide the power supply out of the power supply tray and set aside.

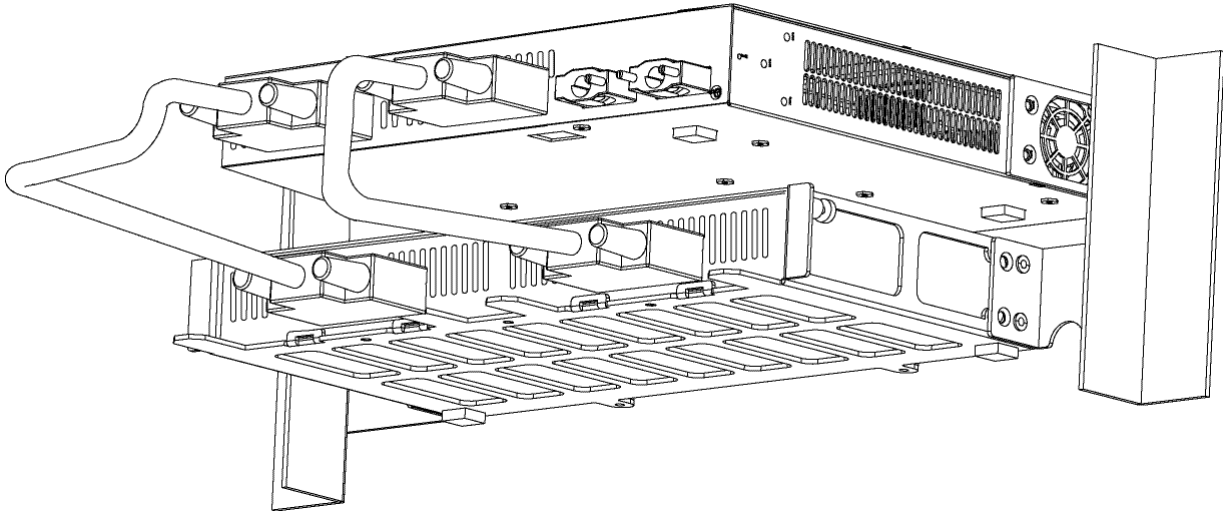

Rack-Mounted Power Supplies

- 5** Carefully slide the new power supply on to the power supply tray and secure the power supply to the tray using the captive screw.
- 6** Reconnect the power supply cable of the new power-supply and tighten securely.
- 7** Re-connect the power supply to its power source.

Rack-Mounting the Chassis

Refer to the important guidelines below before installing the OmniSwitch 6855 Series chassis in a rack.

- It is recommended that two people install the switch in the rack—one person to hold the chassis and position it in the rack, and a second person to secure the chassis to the rack using attachment screws (not supplied).
- Alcatel-Lucent provides two rack-mount flanges with each OmniSwitch 6855 Series switch. These flanges support standard 19-inch rack-mount installations. These flanges must be attached to the chassis before the switch can be rack mounted.

Note. If you are installing the switch in a 23-inch-wide rack, Alcatel-Lucent offers optional 23-inch rack-mounting hardware. For more information, contact your Alcatel-Lucent representative.

- Alcatel-Lucent does not provide rack-mount screws. Use the screws supplied by the rack vendor.
- To prevent a rack from becoming top heavy, it is recommended that you install heavier equipment at the bottom of the rack, whenever possible.
- If you are installing the switch on a relay rack, be sure to install and secure the rack per the rack manufacturer's specifications.
- Review [page 3-1](#) for important chassis airflow and access recommendations before installing.

Rack Mounting Steps

To rack-mount the switch, follow the steps below:

- 1** Align the holes in the provided rack-mount flanges with the four threaded holes in the OmniSwitch 6855 Series chassis. These threaded holes are located in the left and right sides of the chassis, near the front panel.
- 2** Attach the flanges to the chassis using the provided Phillips-head screws. Be sure to tighten each of the screws firmly using a Phillips screwdriver.

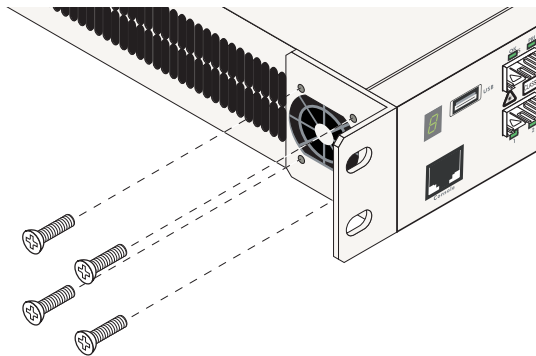

Attaching a Rack-Mount Flange

- 3** After the rack-mount flanges are secured to the chassis, mark the holes on the rack where the switch is to be installed.
- 4** Lift and position the switch until the rack-mount flanges are flush with the rack post.
- 5** Align the holes in the flanges with the rack holes that were marked in step 3.
- 6** Once the holes are aligned, insert a rack mount screw (not provided) through the *bottom hole of each flange*. Tighten both screws until they are secure.

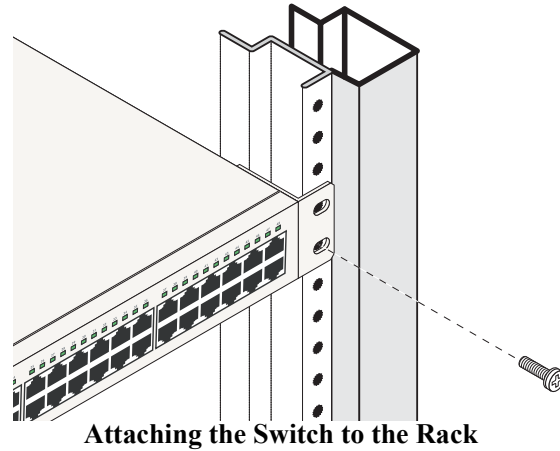

Note. Be sure to install the screws in the *bottom hole* of each flange, as shown, before proceeding.

- 7** Once the screws at the bottom of each flange are secure, install the remaining two rack mount screws. Be sure that all screws are securely tightened.

Table Mounting the Chassis

OmniSwitch 6855 Series switches can be installed freestanding as a tabletop unit.

Note. Be sure that adequate clearance has been provided for chassis airflow and access to the front, back, and sides of the switch. For recommended clearances, refer to “[General Mounting Recommendations](#)” on [page 3-1](#). Also, be sure that you have placed the chassis within the reach of all the required AC power sources.

To install the switch as a tabletop unit, follow the steps below:

- 1 Secure the power supply tray and power supplies to the back of the chassis as described on [page 3-5](#).
- 2 Using the attachment screws supplied with your switch, attach the mounting brackets to the front portion of the chassis. Attach the brackets to both the left and right side of the switch. Be sure that the flat portion of each bracket is facing down. (refer to illustration below).

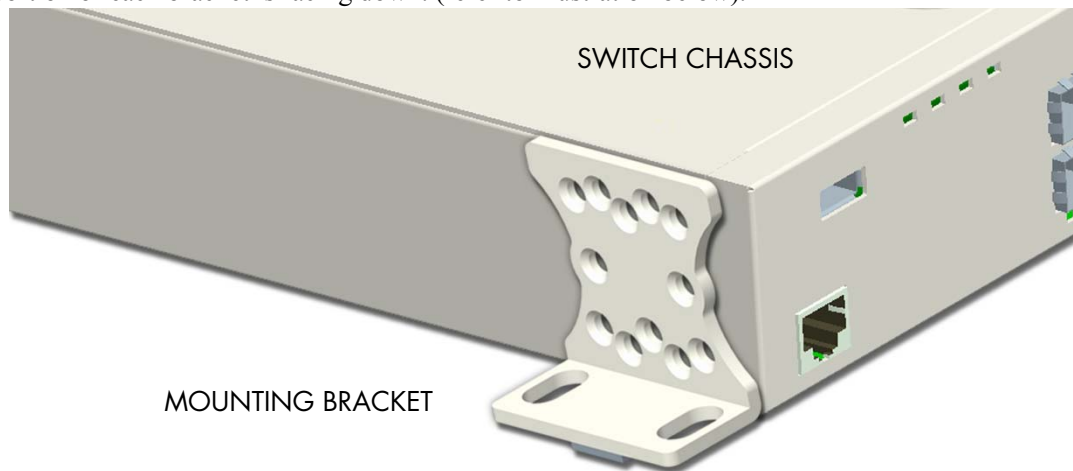

- 3 Using the attachment screws supplied with your switch, attach the mounting brackets to the rear portion of the chassis. Attach the brackets to both the left and right side of the switch. Be sure that the flat portion of each bracket is facing down. (refer to illustration below).



- 4 Mount the switch assembly on the table by inserting attachment screws through the flat portion of the mounting brackets and into the mounting surface.



4 Mounting OS6855-14 and OS6855-U10 Switches

This chapter covers different mounting and installation options for OS6855-14 and OS6855-U10 switches.

Anti-Static Warning. Before handling any components, free yourself of static by wearing a grounding strap, or by grounding yourself properly. Static discharge can damage the switch and the backup power supply.

Chassis Components

OS6855-14 and OS6855-U10 switches ship with all mounting brackets attached. The following diagram shows the default chassis and power supply tray assemblies.

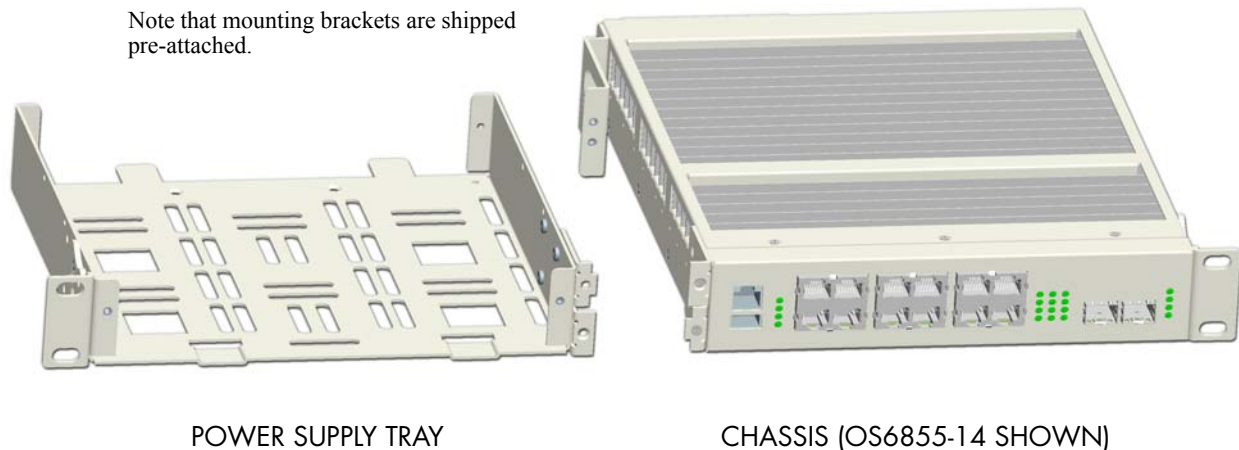

Factory-Shipped Chassis and Power Supply Tray Assemblies

General Installation Recommendations

Cooling Recommendations

OS6855-14 and OS6855-U10 switches are convection-cooled using finned heat sinks. Although air flow is not mandatory for switch operation, *the best way to ensure proper cooling is to provide some ambient air flow over the heat sinks whenever possible* (e.g., from room fans, etc.).

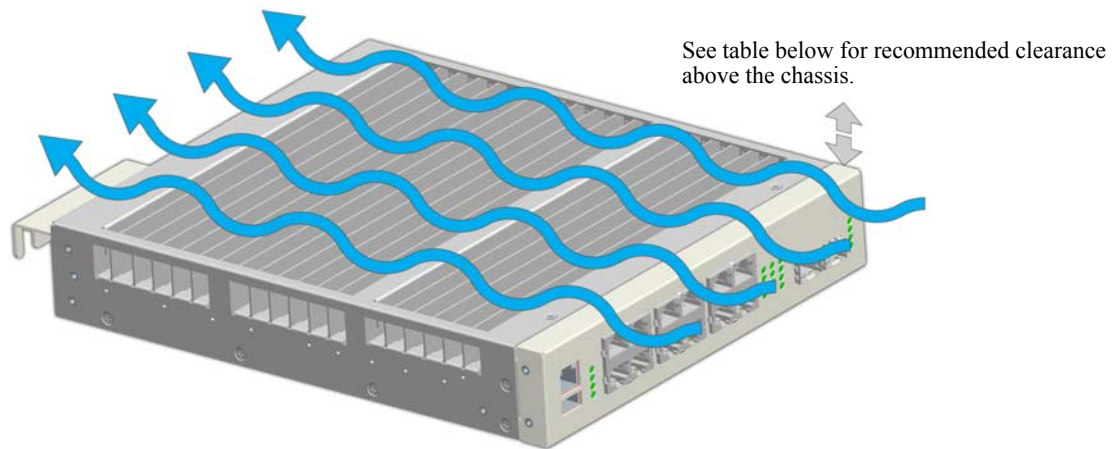

Recommended Airflow Over Heat Sinks

Reduced Air Flow

Installation of the equipment in a rack should be such that the amount of air flow required for safe operation of the equipment is not compromised.

Elevated Operating Ambient Temperatures

If installed in a closed or multi-unit rack assembly, the operating ambient temperature of the rack environment may be greater than room ambient. Therefore, consideration should be given to installing the equipment in an environment compatible with the maximum ambient temperature (T_{ma}) specified by the manufacturer.

Recommended Clearances

Always allow adequate clearance at the front, rear, top, and sides of the switch. The following table shows the recommended minimum clearances for adequate chassis cooling and access to cabling and components at the front and rear of the chassis.

Location	OS6855-14	OS6855-U10
Top	0.875 inches (1/2 RU) for switches operating in an ambient room temperature of 60°C or less. 3.5 inches (2 RU) for switches operating in an ambient room temperature of 70°C (maximum allowable).	0.875 inches (1/2 RU) for switches operating in an ambient room temperature of 60°C or less. 3.5 inches (2 RU) for switches operating in an ambient room temperature of 70°C (maximum allowable).
Bottom	No minimum clearance required. However, be sure that the bottom of the chassis is not in direct contact with any equipment below.	No minimum clearance required. However, be sure that the bottom of the chassis is not in direct contact with any equipment below.
Sides	2 inches	2 inches
Rear	6 inches (see note below)	6 inches (see note below)
Front	6 inches (see note below)	6 inches (see note below)

Note. Clearance recommendations at the front and rear of chassis are for access to cabling and components only and are not intended as a specific airflow requirement.

Mechanical Loading

Mounting of the equipment in the rack should be such that a hazardous condition is not achieved due to uneven mechanical loading.

Circuit Overloading

Consideration should be given to the connection of the equipment to the supply circuit and the effect that overloading of the circuit might have on overcurrent protection and supply wiring. Appropriate consideration of equipment nameplate ratings should be used when addressing this concern.

Reliable Earthing

Reliable earthing of rack-mount equipment should be maintained. Particular attention should be given to supply connections other than direct connections to the branch circuit (e.g. use of power strips).

Power Supply Information

Before getting started, please note that OmniSwitch 6855 Series power supplies can be installed in a number of different configurations. For example:

- Basic single system power, which provides minimum power requirements to the chassis, with no power supply redundancy/failover.
- Redundant system power, which provides minimum power requirements to the chassis as well as power supply redundancy/failover. Two system power supplies (PS1 and PS2) are required for this configuration.
- Basic system power with Power over Ethernet (PoE) support (OS6855-14 only). This provides minimum power requirements to the chassis, as well as minimum power requirements to the OS6855-14 PoE ports. Two system power supplies—a system power supply (PS1) and a PoE-specific power supply—(PoE1) are required for this configuration.
- Redundant system power with Power over Ethernet (PoE) support (OS6855-14 only). This provides system power supply redundancy/failover in addition to PoE power redundancy. Four system power supplies—two system power supplies (PS1 and PS2) and two PoE-specific power supplies—(PoE1 and PoE2) are required for this configuration.

Refer to the table below for typical power supply and power supply tray requirements for different configurations.

Power requirements	Power supplies needed	Power supply trays needed
Basic power (no redundancy)	1	1
Chassis power redundancy	2	1
Basic power with PoE	2	1
Chassis power redundancy with PoE	4	2

Rack-Mounting OS6855-14 and OS6855-U10 Switches

General Rack-Mounting Guidelines

If you will be rack-mounting your OS6855-14 and OS6855-U10 switch(es), refer to the important guidelines below before installing.

- It is recommended that two people install the switch assembly on the rack—one person to hold the chassis and position it on the rack, and a second person to secure the chassis to the rack using attachment screws. (Please note that Alcatel-Lucent does not provide rack-mount screws. Use the screws supplied by the rack vendor.)
- To prevent a rack from becoming top heavy, it is recommended that you install heavier equipment at the bottom of the rack, whenever possible.
- Review [page 4-3](#) for recommended chassis clearances before installing.
- If you are installing the switch on a relay rack, be sure to install and secure the rack per the rack manufacturer's specifications.

Positioning the Power Supply Tray(s)

When rack mounting the switch, the power supply tray is positioned at the left side of the unit assembly by default. This allows the chassis and power supply assembly to span the full width of the rack.

If both redundant chassis power *and* Power over Ethernet (PoE) are to be used with the OS6855-14, an additional power supply tray must be mounted immediately behind the switch chassis. Refer to the table on [page 4-4](#) for additional power supply requirements.

Detailed instructions for installing power supplies and power supply trays are provided in this section.

Installation

- 1** To mount a single OS6855-14 or OS6855-U10 chassis in a rack, begin by removing the S-bracket located at the left-rear portion of the switch chassis. Once removed, set the bracket and attachment screws aside; they will need to be re-installed later.

Remove the side S-bracket from the chassis by removing the two chassis attachment screws.

Set the bracket and attachment screws aside.

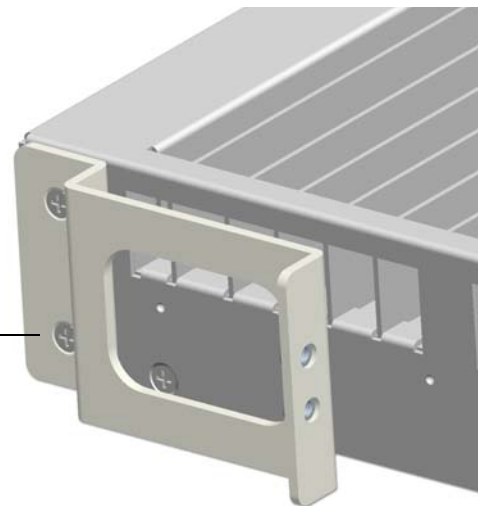

- 2 Attach the S-bracket that was removed at step 1 to the right-rear portion of the power supply tray, as shown. Use the single power supply tray attachment screw (provided).

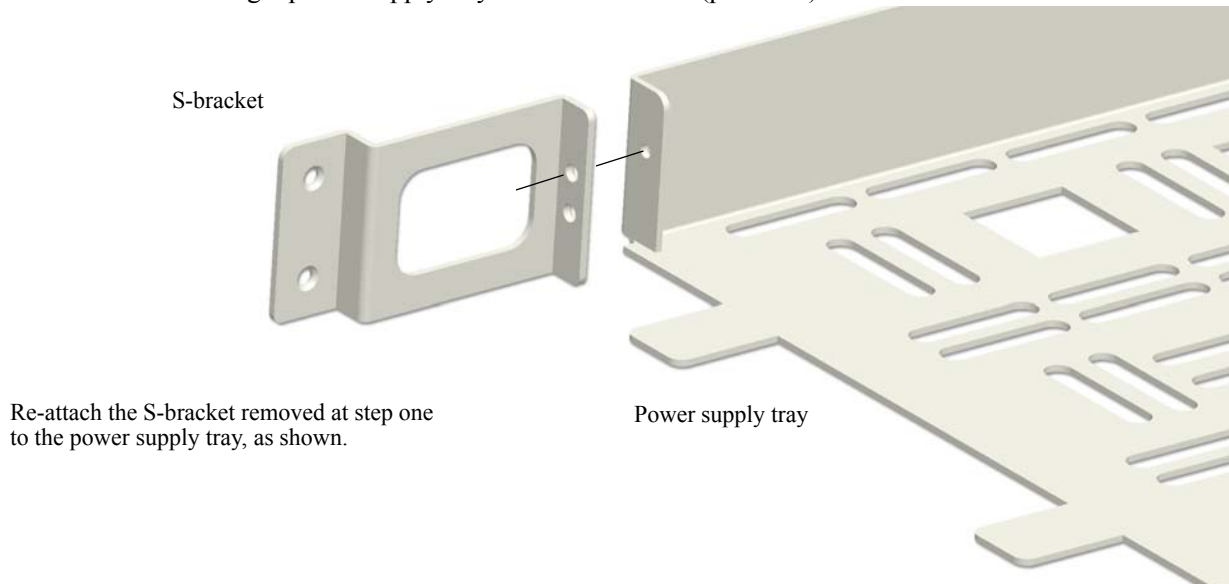

- 3 Next, plug the connector cable from your power supply into the PS1 port located in the back of the switch chassis, as shown.

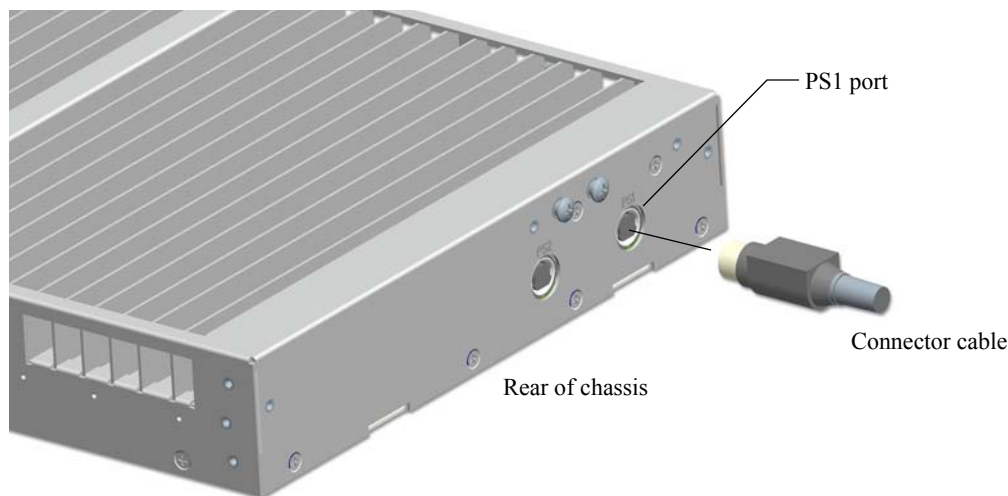

- 4 If no additional power supplies are required, skip to step 5. Otherwise, refer to the additional information on the following configurations: redundant chassis power, PoE, and redundant chassis power with PoE.

Redundant Chassis Power

For OS6855-14 or OS6855-U10 switches using redundant chassis power, a second power supply is required.

For this configuration, plug the connector cable from the second power supply into the PS2 port on the rear panel of the chassis.

When complete, continue to step 5.

PoE Configurations (OS6855-14 only)

OS6855-14 switches using PoE also require a second power supply. This second power supply is a PoE-specific unit included with your Alcatel-Lucent product shipment.

Note. To distinguish PoE power supplies from standard system power supplies, note that PoE supplies have both a long and short connector cable hard-wired into the power supply brick, while standard system power supplies have only a single, long connector cable.

For this configuration, plug the longer connector cable from the PoE power supply into the PoE1 port on the rear panel of the chassis.

Next, connect the shorter PoE connector cable to the female AC connector on the system power supply installed at step 2.

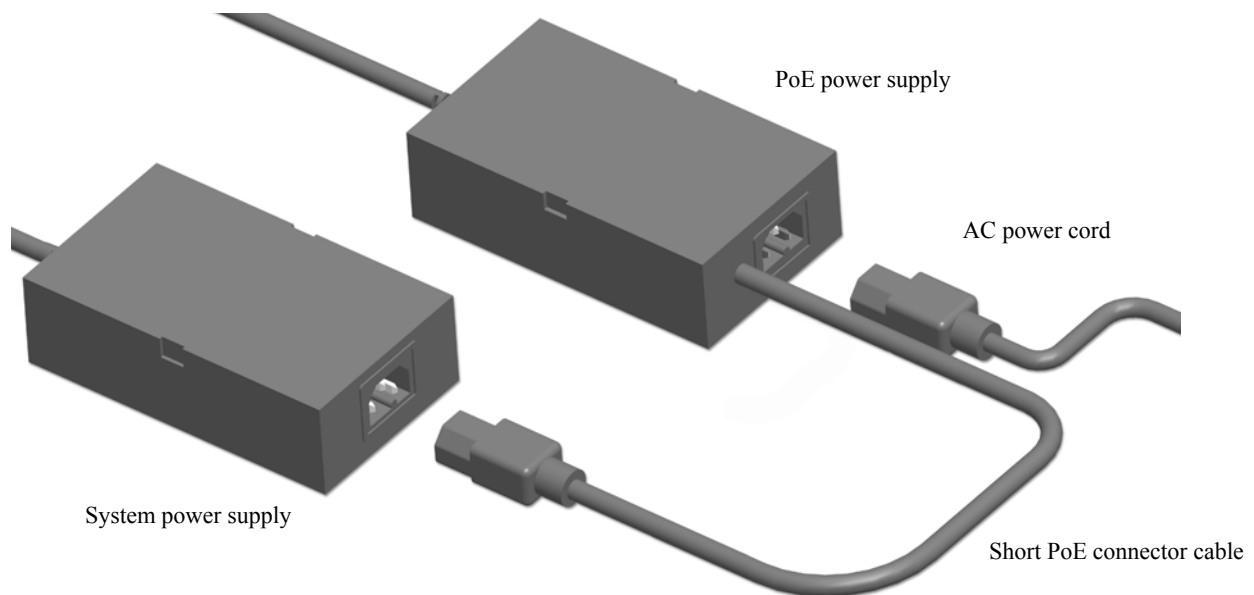

When complete, continue to step 5.

Redundant Chassis Power with PoE (OS6855-14 only)

For OS6855-14 switches using redundant chassis power *in addition to* PoE, a total of four power supplies are required.

For this configuration, plug a second Alcatel-Lucent-provided system power supply into the PS2 port on the rear panel of the chassis.

Next, plug the longer connector cable from one of the Alcatel-Lucent-provided PoE power supplies into the PoE1 port on the rear panel of the chassis, then connect the shorter connector cable to the female AC connector on the system power supply installed at step 2.

Plug the longer connector cable from the second PoE power supply into the PoE2 port on the rear panel of the chassis, then connect the shorter cable to the female AC connector on the remaining system power supply.

When complete, continue to step 5.

5 Place the power supply (or supplies) into the power supply tray with the connector cables facing forward.

Note. For switches using redundant chassis power with PoE, place the power supplies connected to the PS1 and PoE1 ports side-by-side in the tray. The power supplies connected to ports PS2 and PoE2 will be placed in an additional power supply tray later in the installation.

6 Position the power supply retaining strap over the power supplies. Insert the retaining strap's tabs into the notches located on the left and right sides of each power supply in order to hold each power supply firmly in place. Be sure that the tabs are completely inserted in the power supply notches and that the end flanges of the retaining strap fit *inside* the walls of the power supply tray.

7 Secure the retaining strap to the power supply tray using the attachment screws (provided).

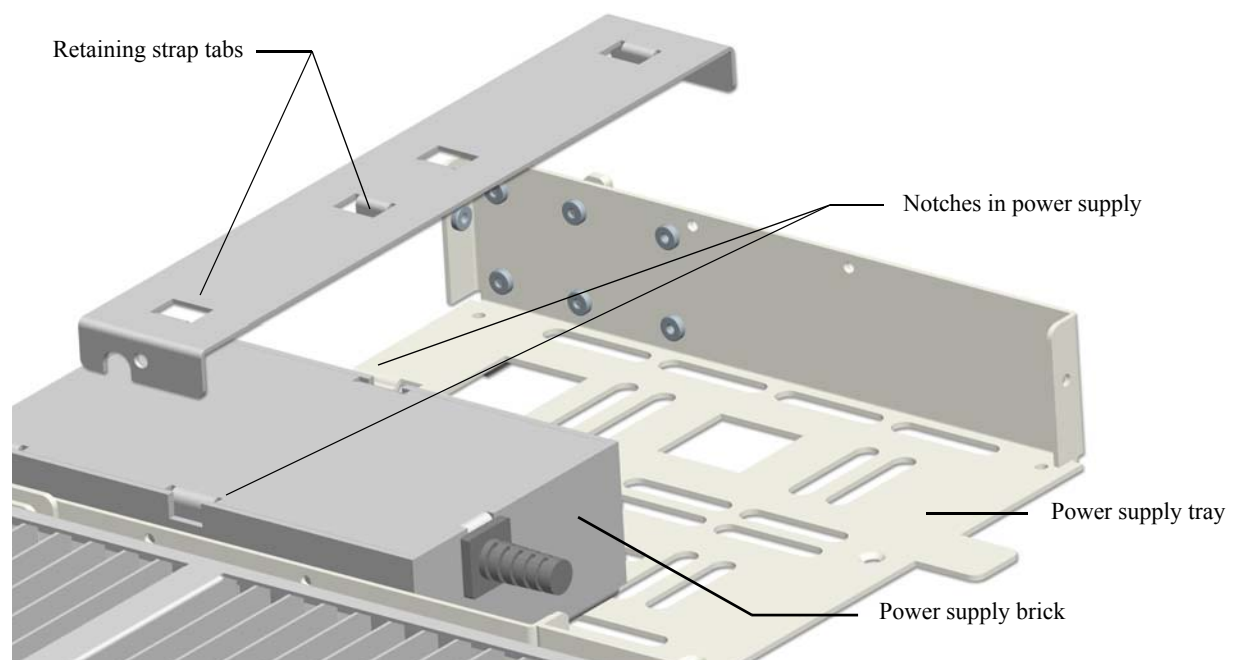

8 Position the switch chassis immediately to the right of the power supply tray and attach the tray's right-front mounting flange to the left-front chassis mounting flange using two attachment screws (provided).

9 Re-attach the S-bracket to the left-rear portion of the chassis using the attachment screws removed at step 1.

10 If no additional power supply trays are required, skip to step 16. Otherwise, refer to additional information on redundant chassis power with PoE, below.

Redundant Chassis Power with PoE (OS6855-14 only)

For OS6855-14 switches using redundant chassis power with PoE, an additional power supply tray is required. This power supply tray is included with all shipments for which redundant chassis power *and* PoE have been specified as requirements. To install the second power supply tray, see steps 11 through 15 below.

11 Insert the two tabs at the base of the tray into the slots provided at the bottom-rear portion of the switch chassis.

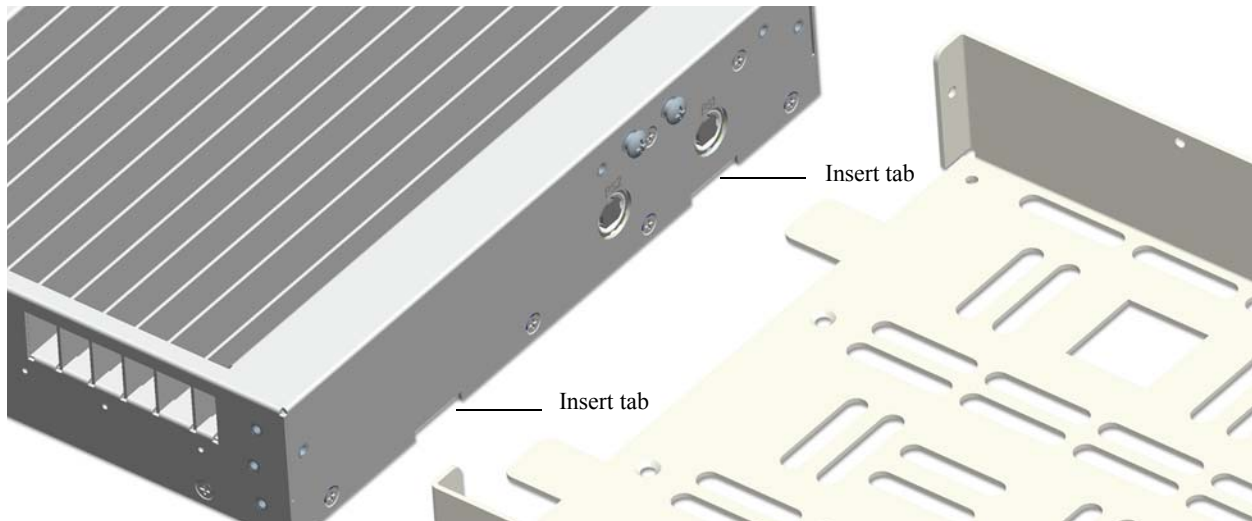

12 Be sure that the two holes in the tray are aligned with the threaded holes in the rear panel of the chassis and secure the tray to the switch using the two attachment screws (provided).

13 Place the PoE power supplies into the power supply tray with the connector cables facing forward.

14 Position the power supply retaining strap over the PoE power supplies. Insert the retaining strap's tabs into the notches located on the left and right sides of each power supply. Again, be sure that the tabs are completely inserted in the power supply notches and that the end flanges of the retaining strap fit *inside* the walls of the power supply tray.

15 Secure the retaining strap to the power supply tray using the attachment screws (provided).

16 Plug the power supply cord into the female AC connector located on the back of each power supply brick.

Note. For PoE configurations, the system power supplies will already have power cords plugged into the AC connectors. Plug the power supply cord into the female AC connector in each PoE power supply, as applicable.

Note. Use only the power cord(s) supplied with your OmniSwitch. The power supply's female AC connector includes a small notch that restricts the installation of many standard, non-OS6855 AC power cords. Never force the power cord into the female AC connector.

17 Install one cord retainer bracket to the back of each installed power supply using the attachment screws (provided). Once all retainer clips are attached, place the slotted retainer clip over the bracket with the retainer fingers pointing down and slide the retainer bracket toward the power supply until it meets the power cord connector. Insert two screws (provided) into the retainer clip slots and tighten until secure.

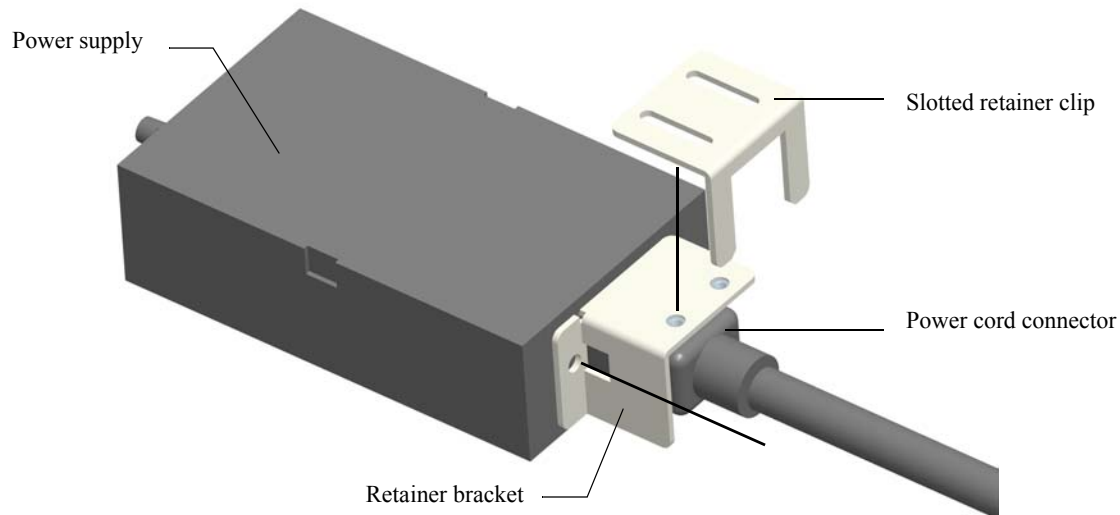

Power Cord Retainer Clip Assembly

18 Now that the chassis and power supply tray(s) are assembled, mark the holes on the rack where the switch assembly is to be installed.

19 Using one additional person, lift and position the chassis/power supply assembly on the rack until the rack-mount flanges are flush with the rack post.

20 Align the holes in the flanges with the rack holes that were marked in step 18.

21 Once the holes are aligned, insert a rack mount screw (not provided) through the *bottom hole of each flange*. Tighten both screws until they are secure.

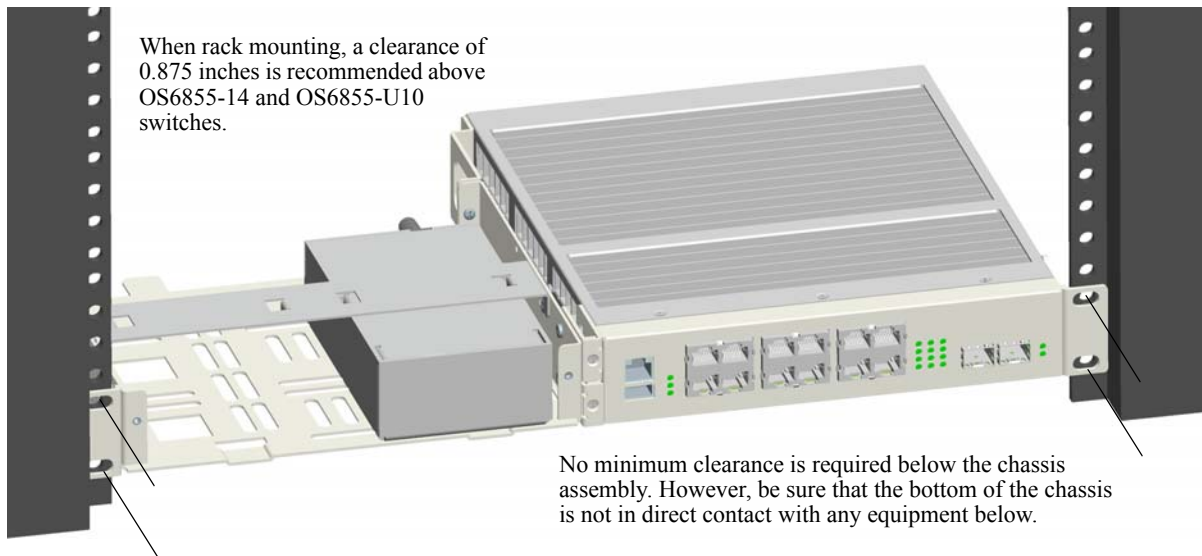

Note. Be sure to install the screws in the *bottom hole* of each flange, as shown, before proceeding.

22 Once the screws at the bottom of each flange are secure, install the remaining two rack mount screws. Be sure that all screws are securely tightened.

Additional Rack Mounting Options

Depending on the number of power supplies, power supply trays, and chassis, the OS6855 can be mounted in a variety of ways as shown below.

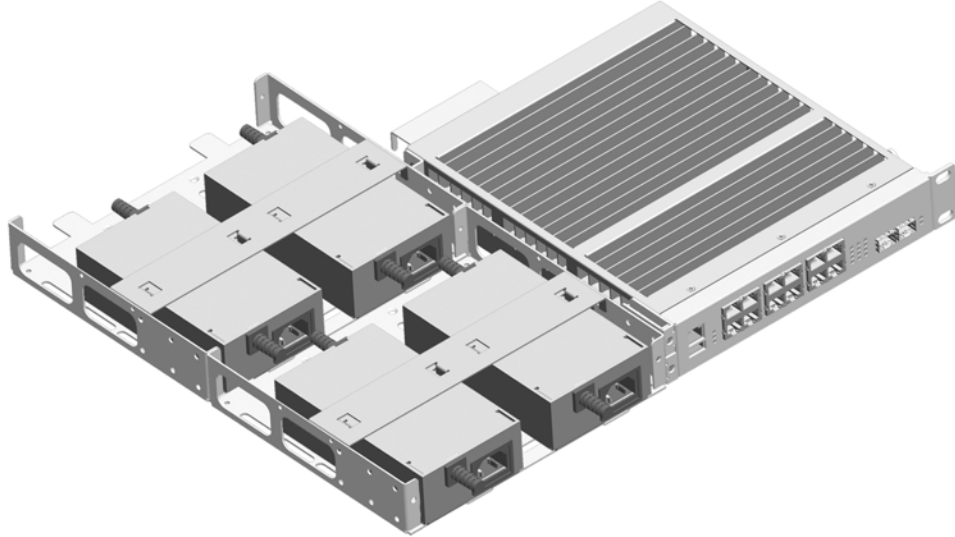

Redundant System and PoE Power Supplies - Side Mount

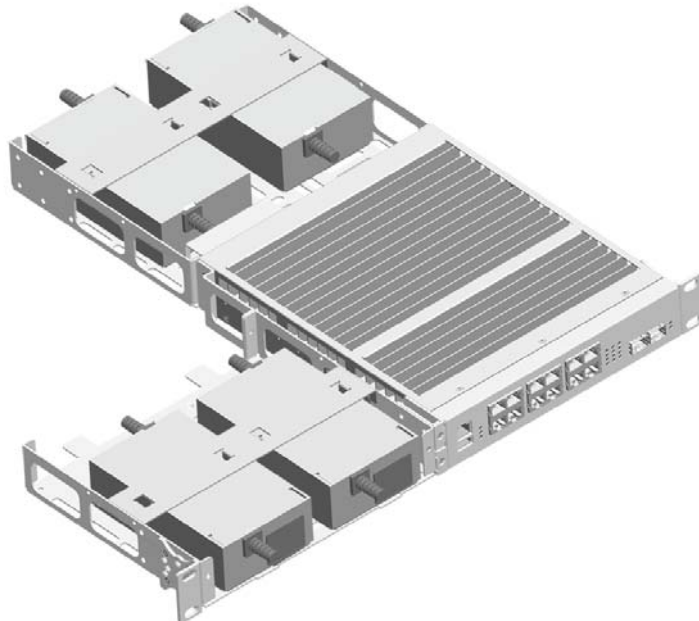

Redundant System and PoE Power Supplies - Side/Rear Mount

Table-Mounting OS6855-14 and OS6855-U10 Switches

General Table-Mounting Guidelines

OmniSwitch 6855 Series switches can be installed freestanding as tabletop-mounted units. If you will be table-mounting your OS6855-14 and OS6855-U10 switch(es), refer to the important guidelines below before installing.

- When choosing a location for the switch, be sure that adequate clearance has been provided for chassis airflow and access to the front, back, and sides of the chassis. For recommended clearances, refer to [“Recommended Clearances” on page 4-3](#).
- The power cord for OmniSwitch 6855 switches measures two (2) meters (approximately 6.5 feet) in length. When table mounting the switch, be sure that the mounting location is within the reach of all the required power sources.

Positioning the Power Supply Tray(s)

When table-mounting the switch, the power supply tray may be positioned either at the left side of the chassis or directly behind the chassis.

This section will detail steps for installing the power supply tray directly behind the OS6855 chassis. For instructions on installing the power supply tray at the left side of the chassis, refer to steps 1 through 17, beginning on [page 4-5](#). When complete, return to this section for additional table-mounting steps.

Installation

- 1** To install the switch as a tabletop unit, begin by removing the S-bracket located at the left-rear portion of the switch chassis. Once removed, set the bracket and attachment screws aside and store in a safe place in case another mounting configuration is preferred at a later date.

Remove the side S-bracket from the chassis by removing the two chassis attachment screws.

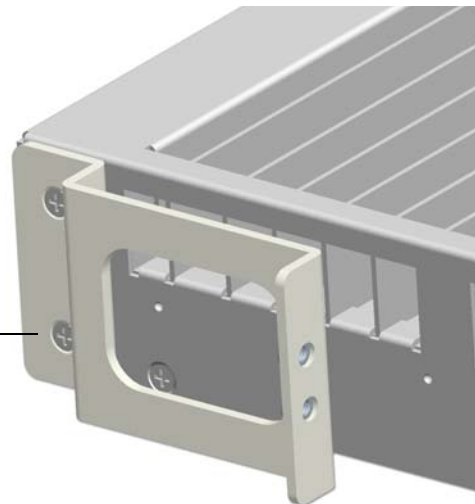

2 Next, insert the two tabs at the base of the power supply tray into the slots provided at the bottom-rear portion of the switch chassis. Secure the power supply tray to the rear of the chassis using the attachment screws (provided).

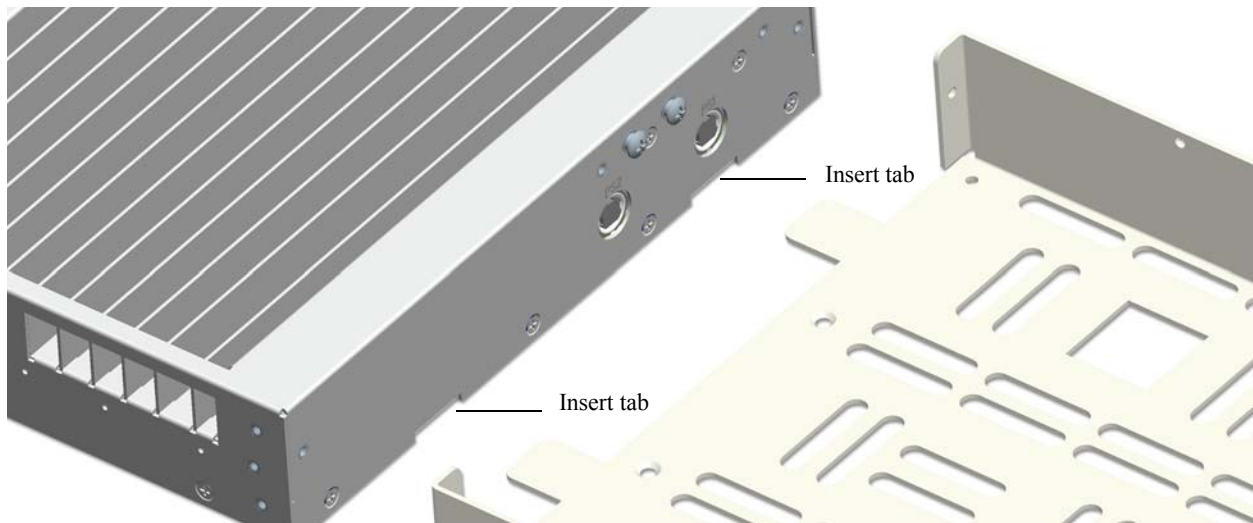

3 Plug the connector cable from your power supply into the PS1 port located in the back of the switch chassis, as shown.

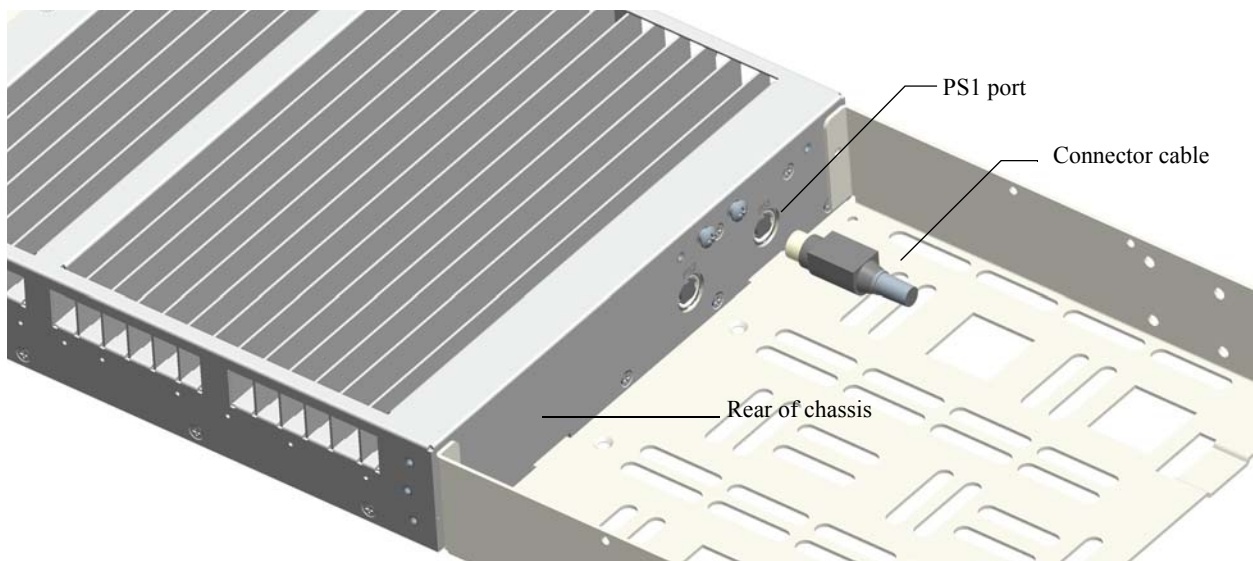

4 If no additional power supplies are required, skip to step 5. Otherwise, refer to the additional information on the following configurations: redundant chassis power, PoE, and redundant chassis power *with PoE*.

Redundant Chassis Power

For OS6855-14 or OS6855-U10 switches using redundant chassis power, a second power supply is required.

For this configuration, plug the connector cable from the second power supply into the PS2 port on the rear panel of the chassis.

When complete, continue to step 5.

PoE Configurations (OS6855-14 only)

OS6855-14 switches using PoE also require a second power supply. This second power supply is a PoE-specific unit included with your Alcatel-Lucent product shipment.

Note. To distinguish PoE power supplies from standard system power supplies, note that PoE supplies have both a long and short connector cable hard-wired into the power supply brick, while standard system power supplies have only a single, long connector cable.

For this configuration, plug the longer connector cable from the PoE power supply into the PoE1 port on the rear panel of the chassis.

Next, connect the shorter PoE connector cable to the female AC connector on the system power supply installed at step 2.

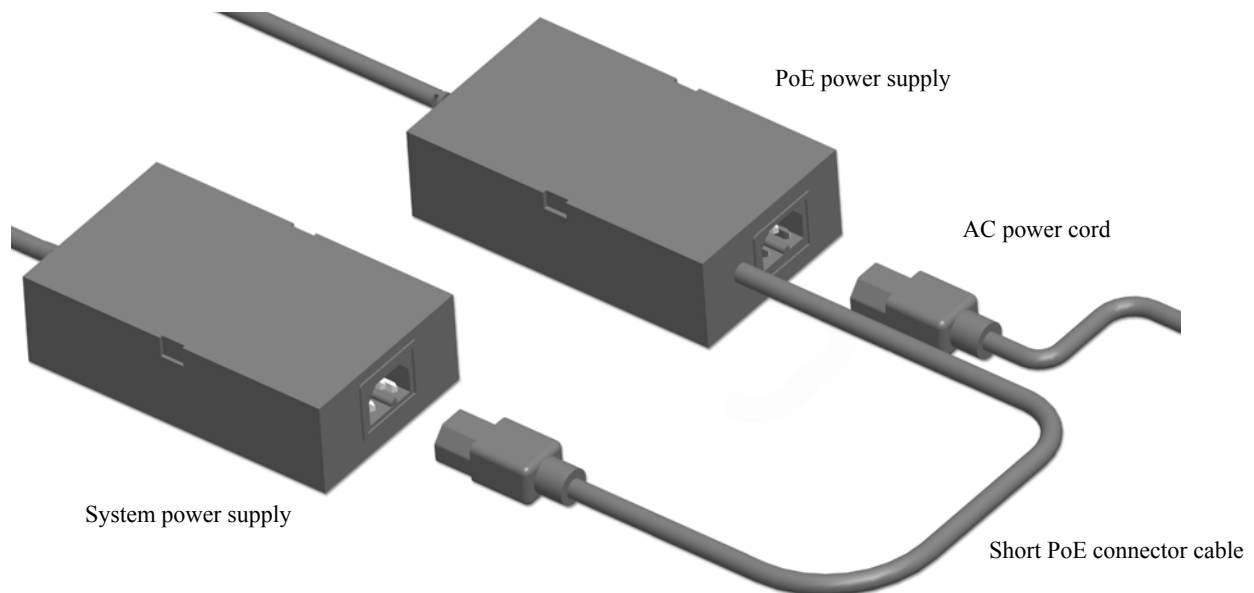

When complete, continue to step 5.

Redundant Chassis Power with PoE (OS6855-14 only)

For OS6855-14 switches using redundant chassis power *in addition to* PoE, a total of four power supplies are required.

For this configuration, plug a second Alcatel-Lucent-provided system power supply into the PS2 port on the rear panel of the chassis.

Next, plug the longer connector cable from one of the Alcatel-Lucent-provided PoE power supplies into the PoE1 port on the rear panel of the chassis, then connect the shorter connector cable to the female AC connector on the system power supply installed at step 2.

Plug the longer connector cable from the second PoE power supply into the PoE2 port on the rear panel of the chassis, then connect the shorter cable to the female AC connector on the remaining system power supply.

When complete, continue to step 5.

5 Place the power supply (or supplies) into the power supply tray with the connector cables facing forward.

Note. For switches using redundant chassis power with PoE, place the power supplies connected to the PS1 and PoE1 ports side-by-side in the tray. The power supplies connected to ports PS2 and PoE2 will be placed in an additional power supply tray later in the installation.

6 Position the power supply retaining strap over the power supplies. Insert the retaining strap's tabs into the notches located on the left and right sides of each power supply in order to hold each power supply firmly in place. Be sure that the tabs are completely inserted in the power supply notches and that the end flanges of the retaining strap fit *inside* the walls of the power supply tray.

7 Secure the retaining strap to the power supply tray using the attachment screws (provided).

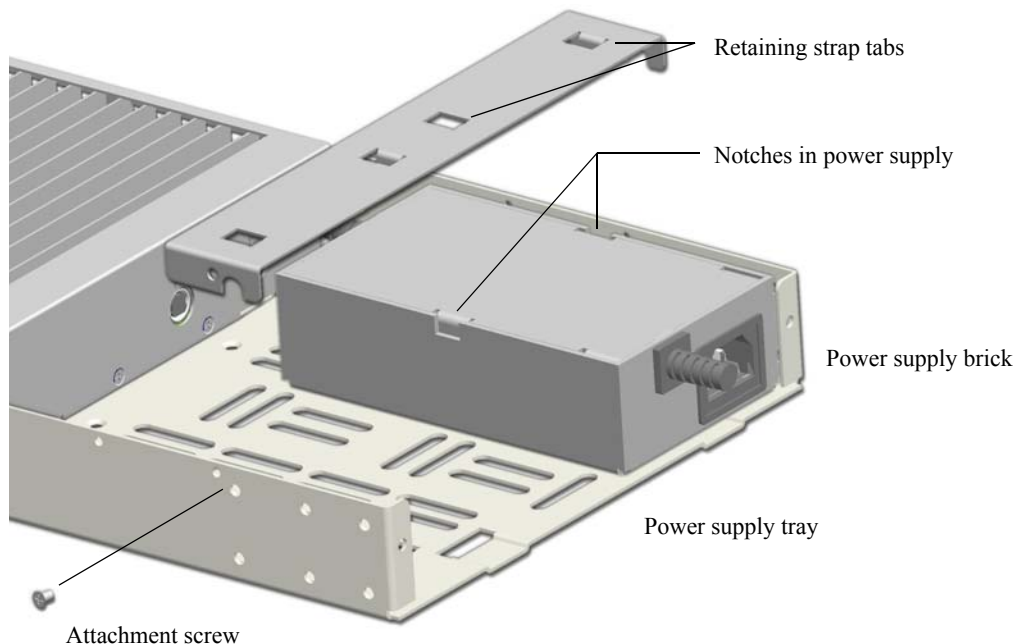

8 Plug the power supply cord into the female AC connector located on the back of each power supply brick.

Note. For PoE configurations, the system power supplies will already have power cords plugged into the AC connectors. Plug the power supply cord into the female AC connector in each PoE power supply, as applicable.

Note. Use only the power cord(s) supplied with your OmniSwitch. The power supply's female AC connector includes a small notch that restricts the installation of many standard, non-OS6855 AC power cords. Never force the power cord into the female AC connector.

9 Install one cord retainer bracket to the back of each installed power supply using the attachment screws (provided). Once all retainer clips are attached, place the slotted retainer clip over the bracket with the retainer fingers pointing down and slide the retainer bracket toward the power supply until it meets the power cord connector. Insert two screws (provided) into the retainer clip slots and tighten until secure.

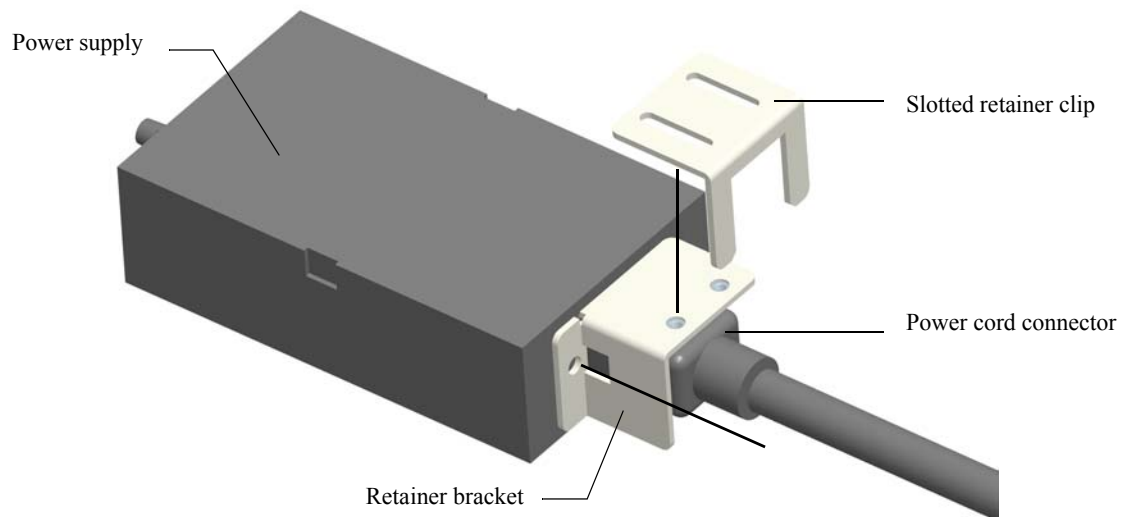

10 If no additional power supplies are required, skip to step 11. Otherwise, refer to the additional information on redundant chassis power with PoE below.

Redundant Chassis Power with PoE (OS6855-14 only)

If the switch requires both redundant power *and* PoE, a minimum of four (4) power supplies is required (see [page 4-4](#) for more information). To accommodate four power supplies, a second power supply tray must be installed directly behind the first power supply tray.

To install the second power supply tray, insert the two tabs at the base of the power supply tray into the grooves provided at the bottom-rear portion of the first power supply tray. Secure the second power supply tray to the first power supply tray using the attachment screws (provided), then install the additional power supply bricks by repeating steps 2 through 6 of this section.

11 Now that the chassis and power supply tray(s) are assembled, remove the honey-combed attachment brackets from the front of the chassis and power supply tray. These brackets will be replaced with brackets with pre-attached rubber bumpers. The rubber bumpers allow optimum spacing between the chassis and table surface, provide additional shock absorbing, and help protect the table surface from damage caused by contact with the metal flange.

12 Locate the table-mount brackets provided in your ship kit and orient the brackets so that the rubber bumpers are facing down. Attach the brackets to both the left and right side of the switch, as shown.

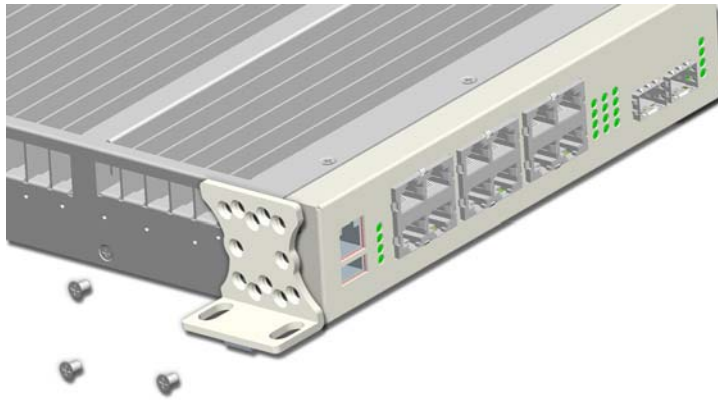

13 Attach two additional mounting brackets (provided) to the rear portion of the chassis so that the rubber bumpers are facing down. Attach the brackets to both the left and right side of the switch.

14 Attach the additional mounting brackets (provided) to the rear portion of the power supply tray that was installed at step 1 (again, so that the rubber bumpers are facing down). Attach the brackets to both the left and right side of the tray.

Redundant Chassis Power with PoE (OS6855-14 only)

For redundant chassis power with PoE configurations, attach two additional mounting brackets to the rear portion of the second power supply tray.

15 If preferred, mount the complete switch assembly to the table by inserting attachment screws (not provided) through the flat portion of the mounting brackets and into the mounting surface. Do not over-tighten. Otherwise, the switch/power supply tray assembly may simply be placed on the table surface without attachment screws.

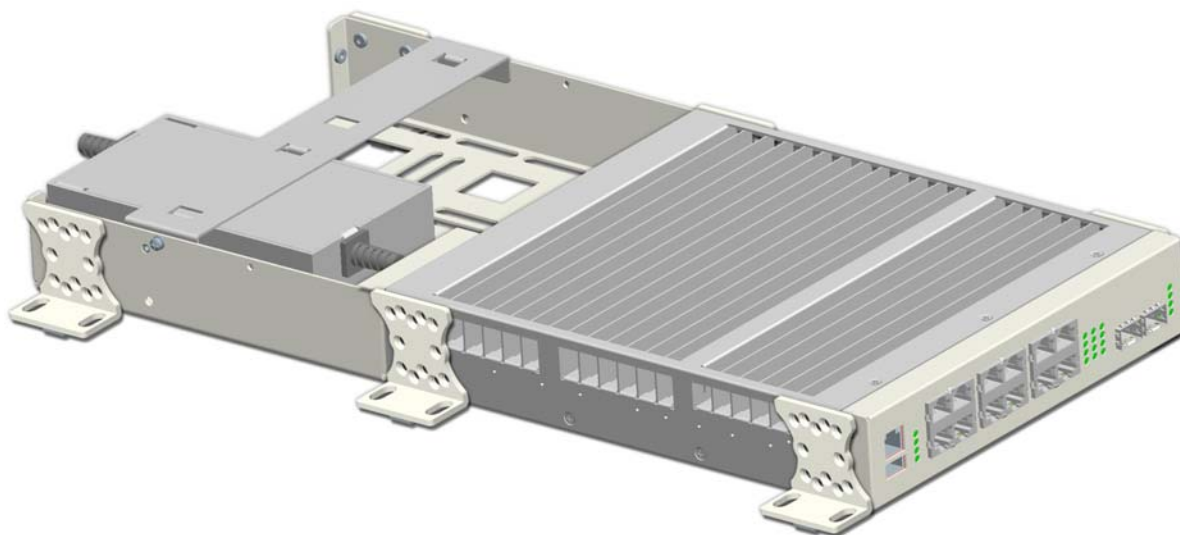

Wall-Mounting OS6855-14 and OS6855-U10 Switches

OmniSwitch 6855 Series switches can also be installed as wall-mounted units.

General Wall-Mounting Guidelines

- When choosing a location for the switch, be sure that adequate clearance has been provided for chassis airflow and access to the front, back, and sides of the chassis. For recommended clearances, refer to [“Recommended Clearances” on page 4-3](#).
- For wall mounting, it is recommended that the chassis assembly is oriented sideways, with the chassis front panel facing left, as shown in the diagram below.
- In order to ensure that damage to the power cord does not occur, steps must be taken to provide proper routing of the power cord, as well as proper access to the switch’s power source (i.e., grounded outlet). Refer to the guidelines listed below for additional details.
- The power cord for OmniSwitch 6855 switches measures two (2) meters (approximately 6.5 feet) in length. When wall mounting the switch, be sure that the mounting location is within the reach of all the required power sources. In addition, the power cord must not be attached to the building surface (e.g., with U-brackets, cord retainer clips, or other fasteners), nor run through walls, ceiling, floors and similar openings in the building structure.
- Be sure that the wall section and wall attachment screws (not provided) have the required strength to easily support the chassis assembly. A complete OS6855-14 or OS6855-U10 chassis assembly—with mounting brackets, power supply tray, and redundant power supplies—weighs approximately 12 lbs.
- For each mounting hole the use of #10 or 5mm screws long enough to penetrate any soft surfaces, such as sheetrock or drywall, and securely attach to a hard surface such as a wall stud is recommended.
- Two people will be required to wall mount the switch: one person to hold the chassis assembly in place and one person to mark the locations for the mounting screws.

Installation

- 1 To wall mount the switch, follow steps 1 through 7 in the [“Table-Mounting OS6855-14 and OS6855-U10 Switches”](#) section above.
- 2 Use one person to securely hold the chassis assembly in position on the wall. Mark the location of the holes in the mounting brackets on the wall.
- 3 Pre-drill the wall (if required).

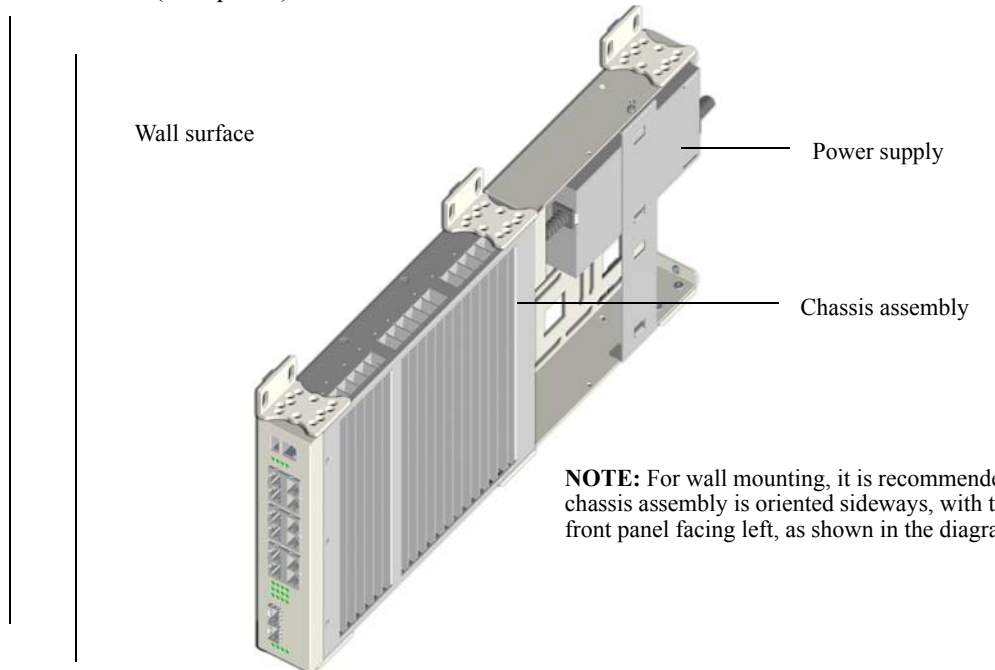

Recommended Wall Mount Chassis Orientation

Note. Wall fasteners are not provided with your switch and will vary depending on the type of wall surface. Be sure to use fasteners that are approved for the full weight of the chassis assembly. Consult fastener specifications for full details.

- 4 Secure the unit to the wall using appropriate wall fasteners.

Hot-Swapping Power Supplies

Hot swapping is supported on some OS6855-14 and OS6855-U10 switches. In order to support the hot swapping of power supplies, the switch must have:

- Redundant system power or redundant PoE power (if hot swapping a PoE supply)
- Power supply tray(s) installed directly behind the switch chassis

Note. Hot swapping power supplies on switches without redundant system power will result in system power interruption and a loss of network connectivity.

To hot swap power supplies, follow the steps below:

- 1** Begin by locating the power supply to be swapped, then disconnect the power cord from its power source. The system will remain operational.
- 2** Remove the two screws located at the top of the power cord retainer bracket. Set the retainer clip and screws aside; they will need to be reinstalled later.

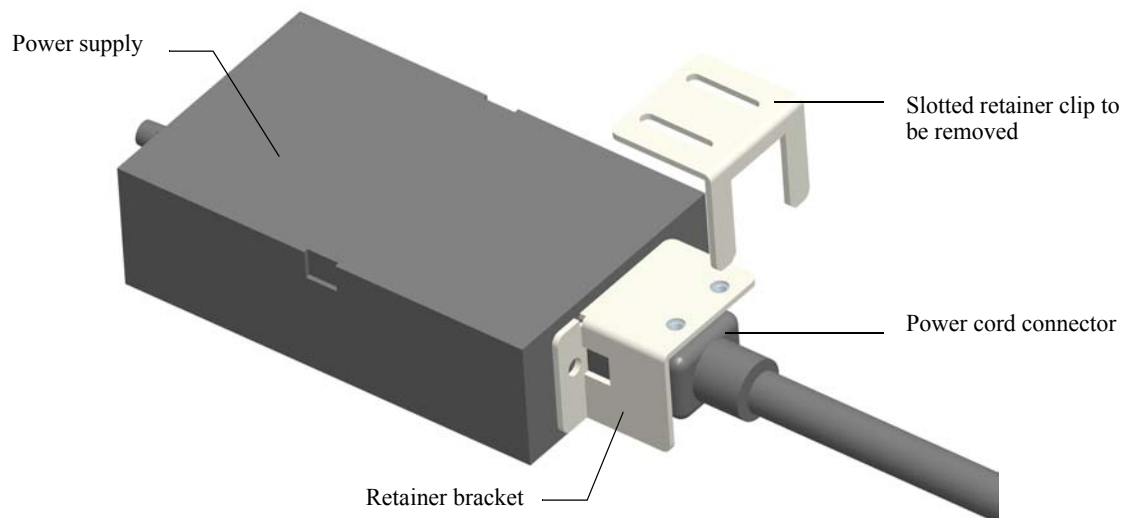

- 3** Unplug the power cord from the power supply.
- 4** Next, remove the two attachment screws used to secure the power supply retaining strap to the power supply tray. Set the screws aside; they will need to be reinstalled later.

- 5 Carefully remove the retaining strap from the power supply tray. Be careful not to disrupt the operational power supply adjacent to the power supply being hot swapped.

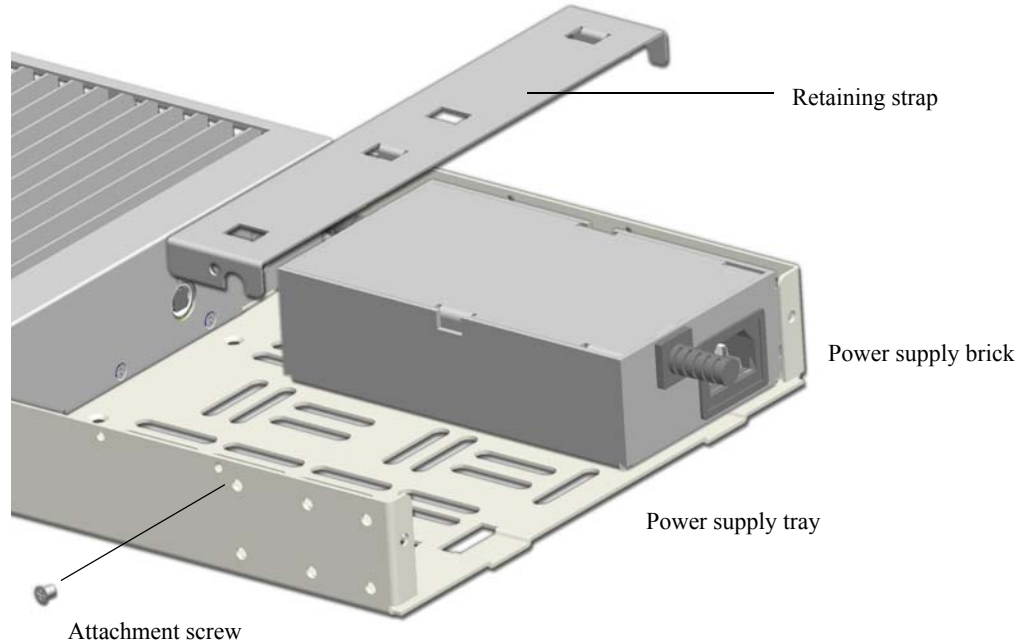

- 6 Lift the power supply that is being hot swapped out of the power supply tray and unplug its connector cable from the PS port located in the back of the switch chassis.

Note for OS6855-14 Switches with Redundant System Power and PoE. If a power supply installed in tray 2 (the farthest power supply tray from the chassis) requires hot swapping, the retaining strap must be removed from tray 1 in order to gain access to the connector cables located at the rear of the chassis.

- 7 Install the new power supply by following the installation steps beginning at step 3 on [page 4-13](#) of this chapter.

Note. If the retaining strap was removed from both trays 1 and 2 in order to gain access to the connector cables, you must reinstall the retaining straps on both trays before the hot swap installation can be considered complete.

5 Booting 6855 Series Switches

For information on booting stand-alone switches and switches in stacked configurations, refer to the sections below.

Booting an OmniSwitch 6855

The OmniSwitch 6855 Series switch does not use an on/off switch. The power cord is the switch's only connect/disconnect device. The power connector socket is located on the power supply rear panel. For more information, refer to [“OmniSwitch 6855 Series Chassis and Hardware Components” on page 2-1](#).

To boot the switch, plug the power cord (provided) into the power connector socket on the power supply. Next, plug the power cord into an easily-accessible power source, such as a grounded AC outlet or an Uninterruptible Power Supply (UPS).

The switch immediately begins the boot process. Allow a few moments for the switch to boot completely, then verify the status of all LEDs on the switch's front panel. A successful boot for a stand-alone switch displays the following LED states:

LED States for a Stand-Alone Switch	
OK	Solid green
PS1	Solid green
PS2	Solid green or OFF if no backup power supply is connected.

If any of the LED state differs from the states shown in the table above, refer to [page 2-7](#) for more information. Contact Alcatel-Lucent Customer Support if the LED state persists.

For information on logging in and configuring your OmniSwitch 6855 Series switch, refer to the OmniSwitch 6855 Series *Getting Started Guide*.

Console Port

The console port, located on the chassis front panel, provides a console connection to the switch and is required when logging into the switch for the first time. By default, this RJ-45 connector provides a DTE console connection.

Serial Connection Default Settings

The factory default settings for the serial connection are as follows:

baud rate	9600
parity	none
data bits (word size)	8
stop bits	1
flow control	none

Modifying the Serial Connection Settings

The switch's serial connection defaults are listed above. If you wish to modify the default serial connection settings (i.e., baud rate, parity, data bits, and stop bits), refer to the following steps:

Note. You must be connected to the switch via the console port before attempting to change serial connection settings. Otherwise, an error message will display.

For switches in a stacked configuration, all changes must be configured before the switches are cabled together. In other words, you must configure these settings when each switch is operating as a stand-alone unit.

-
- 1 Enter the **modify boot parameters** command at the CLI prompt. The boot prompt displays:

```
Boot >
```

- 2 To change the baud rate, enter **boot serialbaudrate**, followed by the desired baud rate value. Options include 1200, 2400, 4800, 9600 (default), 19200, 38400, 57600, 76800, and 115200. For example:

```
Boot > boot serialbaudrate 19200
```

Note. Setting the console port to speeds above 9600 baud can cause problems with Zmodem uploads.

- 3 To change the parity value, enter **boot serialparity**, followed by the desired parity value. Options include none (default), even, and odd. For example:

```
Boot > boot serialparity even
```

- 4 To change the data bits (i.e., word size) value, enter **boot serialwordsize**, followed by the number of data bits. Options include 7 and 8 (default). For example:

```
Boot > boot serialwordsize 7
```

- 5 To change the stop bits value, enter **boot serialstopbits**, followed by the number of stop bits. Options include 1 (default) and 2. For example:

```
Boot > boot serialstopbits 2
```

- 6 Verify your current changes by entering **show** at the boot prompt:

```
Boot > show
Edit buffer contents:
Serial (console) baud      : 19200
Serial (console) parity   : even
Serial (console) stopbits  : 2
Serial (console) wordsize  : 7
```

(additional table output not shown)

- 7 You can save your changes to the **boot.params** file by entering **commit file** at the boot prompt:

```
Boot > commit file
```

When the **commit file** command is used, changes will not be enabled until after the next switch reboot.

- 8 You can also save your changes in real time to the switch's running memory by entering **commit system** at the boot prompt:

```
Boot > commit system
```

Caution. There are two important things to consider when using the **commit system** command to save serial connection changes:

- Output to the terminal may become illegible due to incompatible serial connection settings between the switch and the terminal emulation software.
- If you use the **commit system** command only, changes will *not* be saved to the switch's **boot.params** file and will be lost if the switch is rebooted. To save changes to the **boot.params** file, refer to step 7.

-
- 9 Return to the CLI prompt by entering **exit** at the boot prompt.

Viewing the Power Supply Status

The switch constantly monitors the power supply operation. If either the primary or backup power source (optional) unexpectedly shuts down, the switch sends out a notification to the user. In addition, the power LED on the chassis front panel displays solid amber.

Note. For detailed OmniSwitch 6855 Series LED information, refer to [“Status LEDs” on page 2-16](#).

To check the number of power supplies currently operating, and the status of each power supply, use the **show power** command. For example:

```
-> show power

Power Supplies in chassis 1
PS          Operational Status
-----+-----
PS-1        UP
PS-2        NOT PRESENT
```

The primary (i.e., factory-installed) power supply is listed as **PS-1** in the **show power** command output. The backup power supply is listed as **PS-2**. In the example above, there is no backup power supply installed.

Monitoring the Chassis

OmniSwitch 6855 Series switches can be monitored and managed via the console port using Command Line Interface (CLI) commands. The switches can also be monitored and managed via the Ethernet using CLI commands, WebView, SNMP, and OmniVista.

The section below provides some examples of useful hardware-related monitoring CLI commands. Refer to the *OmniSwitch CLI Reference Guide* for detailed information on all management and monitoring commands used with the OmniSwitch 6855 Series switch.

Checking the Overall Chassis Status

To check the overall status of a chassis, including the chassis type, and current administrative and operational status, use the **show chassis** command. For example:

```
-> show chassis
```

```
Chassis 1
  Model Name:           OS6855-14,
  Description:          12 RJ45 + 2 SFP,
  Part Number:          902632-90,
  Hardware Revision:    B07,
  Serial Number:        H47Q0027,
  Manufacture Date:     JAN 03 2008,
  Admin Status:         POWER ON,
  Operational Status:   UP,
  Number Of Resets:     23
  MAC Address:          00:e0:b1:6b:ef:30,
```

For a complete list of output definitions for this command, refer to the *OmniSwitch CLI Reference Guide*.

Checking the Temperature Status

To check chassis temperature status, including the current temperature and configured threshold values, use the **show temperature** command. For example:

```
-> show temperature
```

```
Temperature for sensor 1
  Hardware Board Temperature (deg C)           = 39,
  Temperature Upper Threshold Range (deg C)     = 14 to 86,
  Temperature Upper Threshold (deg C)          = 80,
  Temperature Status                            = UNDER THRESHOLD,
  Temperature Danger Threshold (deg C)         = 86
```

For a complete list of output definitions for this command, refer to the *OmniSwitch CLI Reference Guide*.

Checking the Fan Status

To check the current status for all six fans in the chassis, use the **show fan** command. For example:

```
-> show fan
Chassis Fan  Status
-----+-----+-----
      1      1  Running
      1      2  Running
      1      3  Running
      1      4  Running
```

For a complete list of output definitions for this command, refer to the *OmniSwitch CLI Reference Guide*.

Checking the Power Supply Status

For information on checking power supplies for OmniSwitch 6855 Series switches, refer to “[Booting 6855 Series Switches](#)” on page 5-1.

Automatic Monitoring

Automatic monitoring refers to the switch’s built-in sensors that automatically monitor operations. The switch receives an interrupt warning at a temperature of 75C. It sends a trap to the user and the switch shuts down automatically when the temperature reaches 80C. Upon cooling (at 65C), the switch restarts.

Additional Monitoring Commands

CLI Commands Used for Monitoring a Chassis

show cmm	Displays the basic hardware and status information for primary and secondary management modules (if applicable).
show ni	Displays the basic hardware and status information for individual modules. If the switch is a standalone, information for the stand alone switch displays.
show module	Displays the basic information for individual modules. If the switch is a standalone, information for the stand-alone switch displays.
show module long	Displays the detailed information for individual modules. If the switch is a standalone, information for the standalone switch displays.
show module status	Displays the basic status information for individual modules. If the switch is a standalone, information for the standalone switch displays.

Using LEDs to Visually Monitor the Chassis

The front panel of OmniSwitch 6855 Series switches provides status LEDs that are useful in visually monitoring the status of standalone switches. Front panel LEDs include:

- Ethernet Port LEDs
- System Status LEDs
- Combo Port Status LEDs

For tables showing LED states operating normally, refer to page [2-16](#).

Installing SFP and XFP Transceivers

For information on installing XFPs and SFPs, refer to the instruction card included with the transceiver.

6 Installing and Managing Power over Ethernet (PoE)

Power over Ethernet (PoE) is supported on OmniSwitch 6855 Series switches and provides inline power directly from the switch's Ethernet ports. Powered Devices (PDs) such as IP phones and wireless APs can be powered directly from the switch's RJ-45 ports.

As the feature reduces devices' dependence on conventional power sources, PoE eliminates many restrictions that traditional electrical considerations have imposed on networks.

In a PoE configuration, Power Source Equipment (PSE) detects the presence of a PD and provides an electrical current that is conducted along the data cable. The PD operates using the power received via the Ethernet data cable; no connection to an additional power source (e.g., an AC wall socket) is required.

Note on Terminology. There are several general terms used to describe the feature, PoE. The terms *Power over Ethernet (PoE)*, *Power over LAN (PoL)*, *Power on LAN (PoL)*, and *Inline Power* are synonymous terms used to describe the powering of attached devices via Ethernet. For consistency, this chapter and the *CLI Command Reference Guide* refer to the feature as *Power over Ethernet (PoE)*.

Additional terms, such as *Powered Device (PD)* and *Power Source Equipment (PSE)* are not synonymous with PoE, but are directly related to the feature:

- *PD* refers to any attached device that uses a PoE data cable as its only source of power. Examples include access points, such as IP telephones, Ethernet hubs, wireless LAN stations, etc.
- *PSE* refers to power sourcing equipment, which provides power to a single link section. PSE main functions include searching the PD, optionally classifying the PD, supplying power to the link section only if the PD is detected, monitoring the power on the link section, and scaling power back to detect level when power is no longer requested or required.

As the OmniSwitch 6855 Series switches fully support 10/100/1000 Ethernet connectivity, you may also attach non-PD equipment, such as computer workstations, printers, servers, etc. to PoE ports. See [Chapter 2, "OmniSwitch 6855 Series Chassis and Hardware Components,"](#) for more information on the OmniSwitch 6850 Series chassis.

Important. Alcatel-Lucent recommends that PoE-enabled switches with attached IP telephones should have operational power supply redundancy at all times for 911 emergency requirements. In addition, both the switch and the power supply should be plugged into an Uninterruptible Power Source (UPS).

In This Chapter

This chapter provides specifications and descriptions of hardware and software used to provide PoE for attached devices.

The chapter also provides information on configuring PoE settings on the switch through the Command Line Interface (CLI). CLI commands are used in the configuration examples; for more details about the syntax of commands, see the *OmniSwitch CLI Reference Guide*. Topics and configuration procedures described in this chapter include:

- Power over Ethernet Specifications on [page 6-3](#)
- Viewing Power Status on [page 6-4](#)
- Configuring Power over Ethernet Parameters on [page 6-5](#)
- Understanding Priority Disconnect on [page 6-8](#)
- Monitoring Power over Ethernet via the CLI on [page 6-11](#)

Note. You can also monitor all chassis components and manage many chassis features, including Power over Ethernet, with WebView, Alcatel-Lucent's embedded web-based device management application. WebView is an interactive and easy-to-use GUI that can be launched from the OmniVista or a web browser. Please refer to *WebView's Online Documentation* for more information.

Power over Ethernet Specifications

The table below lists general specifications for Alcatel-Lucent's Power over Ethernet support. For more detailed power supply and Power Source Equipment (PSE) specifications, refer to [Chapter 2, "OmniSwitch 6855 Series Chassis and Hardware Components."](#)

IEEE Standards supported	IEEE 802.3af
Default PoE administrative status	Enabled
Default PoE operational status	Disabled (PoE must be activated on a switch-by-switch basis via the lanpower start command.)
OmniSwitch 6850 Series platforms supporting PoE	OmniSwitch 6855-24, OmniSwitch 6855-14
Cable distances supported	100 meters (approx.)
Total number of PoE-capable ports per switch	4
Default amount of inline power allocated for each port	15400 milliwatts
Range of inline power allowed for each port	3000–20000 milliwatts
PoE Current draw	Approximately 4.3 Amps
PoE Power Supply	80 Watts (OS6855-C24) 66 Watts (OS6855-C14)

Viewing PoE Power Supply Status

To view the current status of power supplies installed, use the **show power** command, as shown below:

```
-> show power
Slot  PS    Wattage  Type   Status  Location
-----+-----+-----+-----+-----+-----
  1    1      40      AC    UP      External
  1    2      40      AC    UP      External
  1    3      66      AC    UP      External
  1    4      66      AC    UP      External
```

For detailed information on the **show power** command output, refer to the *CLI Command Reference Guide*.

Configuring Power over Ethernet Parameters

Power over Ethernet Defaults

The following table lists the defaults for PoE configuration:

Parameter Description	Command(s)	Default Value/Comments
PoE operational status	lanpower start or lanpower stop	Disabled
Total power allocated to a port	lanpower power	15.4 Watts
Total PoE power allocated to an entire chassis	lanpower maxpower	80 Watts (OS6855-24) 66 Watts (OS6855-14)
Power priority level for a port	lanpower priority	low
Priority disconnect status	lanpower priority-disconnect	Enabled

Understanding and Modifying the Default Settings

The sections below provide information on each of the key components within the Power over Ethernet software. They include information on PoE-related CLI commands. For detailed information on PoE-related commands, refer to the *OmniSwitch CLI Reference Guide*.

Setting the PoE Operational Status

Enabling PoE

By default, Power over Ethernet is *administratively enabled* in the switch's system software. However, in order to physically activate PoE, you must issue the **lanpower start** command on a slot-by-slot basis before any connected PDs will receive inline power.

To activate power to PoE-capable in a switch, enter the corresponding slot number only. For example:

```
-> lanpower start 1
```

If power to a particular port has been disconnected via the **lanpower stop** command, you can reactivate power to the port by specifying both the *slot* and *port* in the command line. For example:

```
-> lanpower start 1/1
```

Note. You cannot use the *slot/port* syntax to initially activate PoE on a port. This syntax is intended only to reactivate power to those that have been disconnected via the **lanpower stop** command. To initially activate PoE, you must use the **lanpower start slot** syntax only, as described above.

Disabling PoE

To disable PoE on a particular slot or port, use the **lanpower stop** command.

To disable PoE on a *specific PoE-capable port*, enter a *slot/port* number. For example:

```
-> lanpower stop 1/4
```

To disable PoE for *all PoE-capable in a slot*, enter the corresponding slot number only. For example:

```
-> lanpower stop 1
```

Configuring the Total Power Allocated to a Port

By default, PoE automatically allocates 15400 milliwatts for each port on the OmniSwitch 6855 Series switch. In other words, each port is authorized by the system software to use up to 15400 milliwatts to power any attached device.

You can either increase or decrease this value. Values may range from 3000 to 20000 milliwatts.

Increasing the total power allocated to an individual port may provide a more demanding Powered Device (PD) with additional power required for operation. Decreasing the total power allocated to a port helps to preserve inline power and assists in the overall management of the switch's power budget.

To increase or decrease the total power allocated to an individual port, use the **lanpower power** command. Since you are setting the power allowance for an individual port, you must specify a *slot/port* number in the command line. For example, the syntax

```
-> lanpower 1/1 power 3000
```

reduces the power allowance on port 1 of the switch to 3000 milliwatts. This new value is now the maximum amount of power the port can use to power any attached device (until the value is modified by the user).

Configuring the Total Power Allocated to a Switch

Like the maximum port power allowance, the system software also provides a maximum *switch-wide* power allowance. By default, each switch is authorized by the system software to use up to the maximum watts available from the PoE power supply.

As with the maximum port power allowance, the user can either increase or decrease this value. Values may range from 37 watts to the maximum available from the PoE power supply.

Increasing the total power allocated to a switch may provide more demanding Powered Devices (PDs) with additional power required for operation. Decreasing the total power allocated helps preserve inline power and assists in the overall management of the switch's power budget.

Important. Before changing the maximum slot-wide power allowance, you must disable PoE for the slot via the **lanpower stop** command. Once the new value is assigned, re-enable PoE for the slot via the **lanpower start** command.

To increase or decrease the total power allocated to a slot, use the **lanpower maxpower** command. Since you are setting the power allowance for an individual slot, you must specify a *slot* number in the command line. For example, the syntax

```
-> lanpower 1 maxpower 40
```

reduces the power allowance of the OmniSwitch 6850 Series slot 1 to 40 watts. This value is now the maximum amount of power the slot can use to power all attached devices (until the value is modified by the user).

Setting Port Priority Levels

As not all Powered Devices (PDs) connected to the switch have the same priority within a customer network setting, the OmniSwitch 6855 Series switches allow the user to specify priority levels on a port-by-port basis. Priority levels include low, high, and critical. The default priority level for a port is low.

- **Low.** This default value is used for port(s) that have low-priority devices attached. In the event of a power management issue, inline power to low-priority is interrupted first (i.e., before critical and high-priority).
- **High.** This value is used for port(s) that have important, but *not* mission-critical, devices attached. If other in the chassis have been configured as critical, inline power to high-priority is given second priority.
- **Critical.** This value is used for port(s) that have mission-critical devices attached, and therefore require top (i.e., critical) priority. In the event of a power management issue, inline power to critical is maintained as long as possible.

To change the priority level for a particular port, use the **lanpower priority** command. Since the switch allows you to set priority levels on a port-by-port basis, be sure to specify *slot/port* information in the command line. For example, the syntax

```
-> lanpower 1/1 priority critical
```

changes the priority value of port 1 to the highest priority level of critical. Now that the default value has been reconfigured, this port should be reserved for those PDs that are mission critical for network operations.

Understanding Priority Disconnect

The priority disconnect function differs from the port priority function described on [page 6-7](#) in that it applies only to *the addition of powered devices (PDs) in tight power budget conditions*. Priority disconnect is used by the system software in determining whether an incoming PD will be granted or denied power when there are too few watts remaining in the PoE power budget for an additional device. For example, if there are only 2 watts available in the current PoE power budget and a user plugs a 3.5W powered device into a PoE port, the system software must determine whether the device will be powered on. Based on priority disconnect rules, in some cases one or more existing devices may be powered down in order to accommodate the incoming device. In other cases, the incoming device will be denied power.

Priority disconnect rules involve the port priority status of an incoming device (i.e., low, high, and critical), as well as the port's physical port number (i.e., 1/1). Understanding priority disconnect rules is especially helpful in avoiding power budget deficits and the unintentional shutdown of mission-critical devices when PDs are being added in tight power budget conditions. For detailed information on how priority disconnect uses port priority and port number criteria for determining the power status of incoming PDs, refer to the illustrated examples on pages [6-9](#) through [6-10](#).

Reminder. Priority disconnect applies only when there is inadequate power remaining in the power budget for an incoming device.

For information on setting the priority disconnect status, refer to the section below. For information on setting the port priority status (a separate function from priority disconnect), refer to [“Setting Port Priority Levels” on page 6-7](#).

Setting Priority Disconnect Status

By default, priority disconnect is *enabled* in the switch's system software. For information on changing the priority disconnect status, refer to the information below.

Disabling Priority Disconnect

When priority disconnect is disabled and there is inadequate power in the budget for an additional device, power will be denied to *any* incoming PD, regardless of its port priority status (i.e., low, high, and critical) or physical port number (i.e., 1/4).

To disable priority disconnect, use the **lanpower priority-disconnect** command. Since the switch allows you to set priority disconnect status on a slot-by-slot basis, be sure to specify the slot number in the command line. For example, the syntax

```
-> lanpower 1 priority-disconnect disable
```

disables the priority disconnect function on slot 1.

Enabling Priority Disconnect

To enable priority disconnect, use the **lanpower priority-disconnect** command. Be sure to specify the slot number in the command line. For example, the syntax

```
-> lanpower 1 priority-disconnect enable
```

enables priority disconnect on slot 1.

Priority Disconnect is Enabled; Same Priority Level on All PD

Reminder. Priority disconnect examples are applicable only when there is inadequate power remaining to power an incoming device.

When a PD is being connected to a port with the *same priority level* as all other in the slot, the physical port number is used to determine whether the incoming PD will be granted or denied power. Lower-numbered receive higher priority than higher-numbered. In other words, a PD connected to Port 1 will have a higher power priority than a PD connected to Port 2. In order to avoid a power budget deficit, another port in the slot is disconnected. In determining which port to power off, the system software disconnects the port with the highest physical port number.

Priority Disconnect is Enabled; Incoming PD Port has Highest Priority Level

Reminder. Priority disconnect examples are applicable only when there is inadequate power remaining to power an incoming device.

When a PD is being connected to a port with a *higher priority level* than all other in the slot, the incoming PD will automatically be granted power over the other devices, regardless of its physical port number.

In order to avoid a power budget deficit, another port in the slot is disconnected. In determining which port to power off, the system software first selects the port with the lowest configured priority level. For example, if a *critical priority* device is being added to a slot in which five existing devices are attached to *high priority* and one device is attached to a *low priority* port, the low priority port is automatically disconnected, regardless of its physical port number.

If all existing devices are attached to with the same lower priority level, the system software disconnects the port with both the lowest priority level *and* the highest physical port number. For example, if a critical priority device is being added to a slot in which six existing devices are attached to high priority, the high priority port with the highest physical port number is automatically disconnected.

Priority Disconnect is Enabled; Incoming PD Port has Lowest Priority Level

Reminder. Priority disconnect examples are applicable only when there is inadequate power remaining to power an incoming device.

When a PD is being connected to a port with a *lower priority level* than all other in the slot, the incoming PD will be denied power, regardless of its physical port number. Devices connected to other higher-priority will continue operating without interruption.

Priority Disconnect is Disabled

Reminder. Priority disconnect examples are applicable only when there is inadequate power remaining to power an incoming device.

When priority disconnect is disabled, power will be denied to *any* incoming PD, regardless of its port priority status (i.e., low, high, and critical) or physical port number (i.e., 1/1).

Monitoring Power over Ethernet via CLI

To monitor current PoE statistics and settings, use the **show lanpower** command. The command output displays a list of all current PoE-capable, along with the following information for each port:

- Maximum power allocated to the port, in milliwatts
- Actual power used by the port
- Current port status
- Power priority status
- Power on/off status

Aggregate slot and chassis management information is also displayed. This information includes:

- Maximum watts allocated to the corresponding slot
- Amount of power budget remaining that can be allocated for PoE modules
- Total amount of power remaining that can be allocated for additional switch functions

When entering the **show lanpower** command, you must include a valid slot number in the command line syntax. For example:

```
-> show lanpower 1
-> show lanpower 1
Port Maximum(mW) Actual Used(mW) Status Priority On/Off Class
-----+-----+-----+-----+-----+-----+-----
  1      15400           0 Undefined Low OFF None
  2      15400           0 Undefined Low OFF None
  3      15400           0 Undefined Low OFF None
  4      15400           0 Undefined Low OFF None

Slot 1 Max Watts 66
66 Watts Total Power Budget Remaining
66 Watts Total Power Budget Available
2 Power Supplies Available
```

Note. For detailed information on **show lanpower** command output, refer to the *OmniSwitch CLI Reference Guide*.

A Regulatory Compliance and Safety Information

This appendix provides information on regulatory agency compliance and safety for the OmniSwitch 6855 Series switches.

Declaration of Conformity: CE Mark

This equipment is in compliance with the essential requirements and other provisions of Directive 73/23/EEC and 89/336/EEC as amended by Directive 93/68/EEC.

Français: Ce matériel est conformément aux conditions essentielles et à d'autres dispositions de 73/23/EEC et de 89/336/EEC directifs comme modifié par Directive 93/68/EEC.

Deutsch: Konformitätserklärung: CE Kennzeichnung
Diese Anlage ist gemäß den wesentlichen Anforderungen und anderen Bestimmungen richtungweisenden 73/23/EEC und des 89/336/EEC, wie von Directive 93/68/EEC geändert.

Español: Este directivo equipo está en conformidad con los requisitos esenciales y otras provisiones 73/23/EEC y 89/336/EEC según la enmienda prevista por Directive 93/68/EEC.

China RoHS: Hazardous Substance Table

产品说明书附件

SUPPLEMENT TO PRODUCT INSTRUCTIONS

这个文件涉及的是在中华人民共和国境内进口或销售的电子信息产品
Include this document with all Electronic Information Products imported or sold in the People's Republic of China

部件名称 (Parts)	有毒有害物质或元素 (Hazardous Substance)					
	铅 (Pb)	汞 (Hg)	镉 (Cd)	六价铬 (Cr ⁶⁺)	多溴联苯 (PBB)	多溴二苯醚 (PBDE)
电路模块 (Circuit Modules)	×	○	○	○	○	○
电缆及电缆组件 (Cables & Cable Assemblies)	×	○	○	○	○	○
金属部件 (Metal Parts)	×	○	○	○	○	○
塑料和聚合物部件 (Plastic and Polymeric parts)	○	○	○	○	○	○
对于交付时集成了电池的电子信息产品 For electronic information products delivered with integrated functional batteries:						
电池 (Batteries)	○	○	○	○	○	○
<p>○：表示该有毒有害物质在该部件所有均质材料中的含量均在 SJ/T11363-2006 标准规定的限量要求以下。 Indicates that the concentration of the hazardous substance in all homogeneous materials in the parts is below the relevant threshold of the SJ/T11363-2006 standard.</p> <p>×：表示该有毒有害物质至少在该部件的某一均质材料中的含量超出SJ/T11363-2006标准规定的限量要求。 Indicates that the concentration of the hazardous substance of at least one of all homogeneous materials in the parts is above the relevant threshold of the SJ/T11363-2006 standard.</p> <p>对销售之日的所售产品, 本表显示, 阿尔卡特朗讯公司供应链的电子信息产品可能包含这些物质。注意: 在所售产品中可能会也可能不会含有所有所列的部件。 This table shows where these substances may be found in the supply chain of Alcatel-Lucent electronic information products, as of the date of sale of the enclosed product. Note that some of the component types listed above may or may not be a part of the enclosed product.</p>						

除非另外特别的标注, 此标志为针对所涉及产品的环保使用期标志。某些零部件会有一个不同的环保使用期(例如, 电池单元模块)贴在其产品上。
 此环保使用期限只适用于产品是在产品手册中所规定的条件下工作。
 The Environment-Friendly Use Period (EFUP) for all enclosed products and their parts are per the symbol shown here, unless otherwise marked. Certain parts may have a different EFUP (for example, battery modules) and so are marked to reflect such. The Environment-Friendly Use Period is valid only when the product is operated under the conditions defined in the product manual.



Products are packaged using one or more of the following packaging materials:

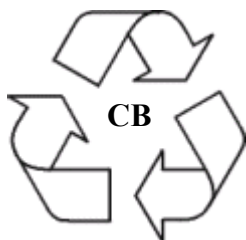

Corrugated Cardboard

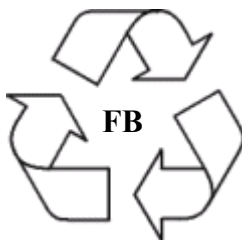

Corrugated Fiberboard



Low-Density Polyethylene

Waste Electrical and Electronic Equipment (WEEE) Statement

The product at end of life is subject to separate collection and treatment in the EU Member States, Norway and Switzerland and therefore marked with the symbol:

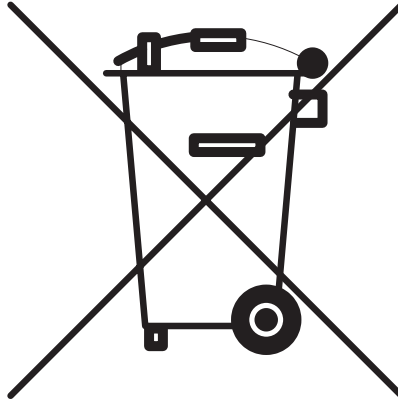

Treatment applied at end of life of the product in these countries shall comply with the applicable national laws implementing directive 2002/96EC on waste electrical and electronic equipment (WEEE).

Standards Compliance

Safety Agency Certifications

- US UL 60950
- IEC 60950-1:2001; all national deviations
- EN 60950-1: 2001; all deviations
- CAN/CSA-C22.2 No. 60950-1-03
- NOM-019 SCFI, Mexico
- AS/NZ TS-001 and 60950:2000, Australia
- UL-AR, Argentina
- UL-GS Mark, Germany
- EN 60825-1 Laser, EN60825-2 Laser
- CDRH Laser
- GOST
- Russian Safety

Note. The USB Connector is for temporary connection only. Do not use, connect, or disconnect unless area is known to be non hazardous. Connection or disconnection in an explosive atmosphere could result in an explosion.

EMI/EMC Standards

- FCC Part 15 (CFR 47) Class A & Class B
- ICES-003, Class A & Class B
- EN 55022 Class A & Class B
- CISPR 22 Class A & Class B
- AS/NZS 3548 Class A & Class B
- VCCI Class A & Class B
- EN 55024
- EN 50082-1
- EN 61000-3-2
- EN 61000-3-3
- EN 61000-4-2
- EN 61000-4-3
- EN 61000-4-4
- EN 61000-4-5
- EN 61000-4-6
- EN 61000-4-8
- EN 61000-6-2

- EN 61000-6-4
- EN 61000-4-11

ETS

- ETS 300 019 Storage Class 1.1
- ETS 300 019 Transportation Class 2.3
- ETS 300 019 Stationary Use Class 3.1

FCC Class A and B, Part 15

This equipment has been tested and found to comply with the limits for Class A and B digital device pursuant to Part 15 of the FCC Rules. These limits are designed to provide reasonable protection against harmful interference when the equipment is operated in a commercial environment. This equipment generates, uses, and can radiate radio frequency energy and, if not installed and used in accordance with the instructions in this guide, may cause interference to radio communications. Operation of this equipment in a residential area is likely to cause interference, in which case the user will be required to correct the interference at his own expense.

The user is cautioned that changes and modifications made to the equipment without approval of the manufacturer could void the user's authority to operate this equipment. It is suggested that the user use only shielded and grounded cables to ensure compliance with FCC Rules.

If this equipment does cause interference to radio or television reception, the user is encouraged to try to correct the interference by one or more of the following measures:

- Reorient the receiving antenna.
- Relocate the equipment with respect to the receiver.
- Move the equipment away from the receiver.
- Plug the equipment into a different outlet so that equipment and receiver are on different branch circuits.

If necessary, the user should consult the dealer or an experienced radio/television technician for additional suggestions.

Canada Class A Statement

This equipment does not exceed Class A limits per radio noise emissions for digital apparatus, set out in the Radio Interference Regulation of the Canadian Department of Communications.

Avis de conformité aux normes du ministère des Communications du Canada

Cet équipement ne dépasse pas les limites de Classe A d'émission de bruits radioélectriques pour les appareils numériques, telles que prescrites par le Règlement sur le brouillage radioélectrique établi par le ministère des Communications du Canada.

JATE

This equipment meets the requirements of the Japan Approvals Institute of Telecommunications Equipment (JATE).

CISPR22 Class A warning

This is a Class A product. In a domestic environment, this product may cause radio interference. Under such circumstances, the user may be requested to take appropriate countermeasures.

VCCI

This is a Class A product based on the standard of the Voluntary Control Council for Interference by Information Technology Equipment (VCCI). If this equipment is used in a domestic environment, radio disturbance may arise. When such trouble occurs, the user may be required to take corrective actions.

この装置は、情報処理装置等電波障害自主規制協議会（VCCI）の基準に基づくクラスA情報技術装置です。この装置を家庭環境で使用すると電波妨害を引き起こすことがあります。この場合には使用者が適切な対策を講ずるよう要求されることがあります。

Class A Warning for Taiwan and Other Chinese Markets

This is a Class A Information Product. When used in a residential environment, it may cause radio frequency interference. Under such circumstances, the user may be requested to take appropriate countermeasure.

警告使用者：
這是甲類的資訊產品，在居住的環境中使用時，可能會造成射頻干擾，在這種情況下，使用者會被要求採取某些適當的對策。

NEBS

- GR-63-CORE (Temp, humidity, altitude, contamination)
- GR-1089-CORE, Issue 4 (Sections 2-3)
- GR-1089-CORE, Issue 4 (Sections 3.2, 4-10)

The following notes and warnings apply to all NEBS compliant platforms:

Grounding requirements: To ground the equipment properly, connect a Panduit Corporation UL listed Lug, P/N: LCD8-10AL to the two threaded holes located on the rear of each chassis and power supply module. All connections should be made using 8AWG copper conductors.

Use Panduit Corporation, P/N: CT-940CH for crimping. (Each Module must have its own grounding conductor.)

(GR-1089 requires treatment of ground connections and painted surfaces as needed during installation.)

All surfaces that are used for intentionally grounding the EUT shall be brought to a bright finish and an anti oxidant solution must be applied to the surfaces being joined.

Non-conductive coatings (such as lacquer and enamel) must be removed from threads and other contact surfaces to assure electrical conductivity.

(Thread forming screws with paint piercing washers may be used for this purpose during installation)

Warning. The intra-building interfaces of this platform, including Gigabit Ethernet, are suitable for connection to intra-building or unexposed wiring or cabling only with shielded and grounded cables at both ends. The intra-building of the equipment must not be metallically connected to interfaces that connect to the OSP or its wiring.

Note. All bare conductors must be coated with an appropriate antioxidant compound before crimp connections are made. All unplated connectors, braided strap, and bus bars are to be brought to a bright finish and then coated with an antioxidant before connecting them.

Commerical

- EMI/EMC FCC Class A and B
- Safety: UL, cUL, CB, GS Mark, UL-AR, NOM, GOST
- Drop Test: Max. 40" drop height
- Altitude Test: 4000m

Industrial

- Operational Temperature: IEC 60870-2-2: -40 °C to +75 °C
- Temperature Type Test (Cold): IEC 60068-2-1: -40 °C, 16 Hrs.
- Temperature Type Test (Hot): IEC 60068-2-2: +80 °C, 16 Hrs.
- Storage Temperature: IEC 60721-3-1: Class 1K5: -40 °C to +85 °C
- Humidity: IEC-60068-2-30, 95% (non-condensing), 55 °C. 6 cycles
- Mechanical Shock: IEC 60255-21-2: 30g 11mS
- Vibration: IEC 60255-21-1: 2g @ 10-150Hz
- Safety: ISA 12.12.01 (UL 1604), CSA22.2/213, UL 508, EN50021
- EMI/EMC: EN61131-2, EN 55022, EN55024, IEC 61000-3-2, IEC 61000-3-3, IEC 61000-4-2, IEC 61000-4-3, IEC 61000-4-4, IEC 61000-4-5, IEC 61000-4-6, IEC 61000-4-8, IEC 61000-4-11, IEC 61000-4-12, IEC 61000-4-16, IEC 61000-4-17, IEC 61000-4-29, IEC 60255-5 & Additional IEEE 1613 (C37.90x)

Military (Navy, Army, Air Force)

- Environmental Testing: MIL-STD-810F: Shock and Vibration

- Environmental Testing: MIL-STD-810F, Methods 500/501/502/503/504/505/506/507/508/509/510/512/
- 514/515/516/520/521 Low Pressure, Low Temperature, High Temperature, Temperature Shock,
- Solar Radiation, Rain, Humidity, Fungus, Salt Fog, Sand and Dust, Immersion, Acoustic Noise,
- Icing/Freezing Rain
- Shock: MIL-STD-901D: <1000 lb, 3 shock/ per axis's/ hammer head.
- Vibration: MIL-STD-167-1: Vibration 4 -33 HZ @30 mil, duration: 8Hr & 40 Min.
- EMI/EMC: MIL-STD-461E: CE101, CE102, CS101, CS114, CS115, CS116, RE101, RE102, RS101, RS103.

Translated Safety Warnings

Chassis Lifting Warning

Two people are required when lifting the chassis. Due to its weight, lifting the chassis unassisted can cause personal injury. Also be sure to bend your knees and keep your back straight when assisting with the lifting of the chassis.

Français: Le châssis doit être soulevé par deux personnes au minimum. Pour éviter tout risque d'accident, maintenez le dos droit et poussez sur vos jambes. Ne soulevez pas l'unité avec votre dos.

Deutsch: Sicherheitshinweise

Hinweise zur Anhebung des Chassis

Zum Anheben des Chassis werden zwei Personen benötigt. Aufgrund des Gewichts kann das Anheben ohne Unterstützung zu Personenschäden führen. Heben Sie das Chassis aus den Knien und halten Sie den Rücken gerade wenn Sie beim Anheben des Chassis assistieren.

Español: Se requieren dos personas para elevar el chasis. Para evitar lesiones, mantenga su espalda en posición recta y levante con sus piernas, no con su espalda.

Blank Panels Warning

Because they regulate airflow and help protect internal chassis components, blank cover plates should remain installed at empty module slots and power supply bays at all times.

Français: Les caches blancs remplissent trois fonctions importantes: ils évitent tout risque de choc électrique à l'intérieur du châssis, ils font barrage aux interférences électromagnétiques susceptibles d'altérer le fonctionnement des autres équipements et ils dirigent le flux d'air de refroidissement dans le châssis. Il est vivement recommandé de vérifier que tous les caches, modules d'alimentation et plaques de protection sont en place avant d'utiliser le système.

Deutsch: Hinweise zu Abdeckungen

Die leeren Modulblenden schützen interne Komponenten und leiten den Luftstrom. Deshalb müssen in allen unbelegten Slots die Modulblenden immer installiert bleiben.

Español: Las tapaderas blancas regulan la circulación de aire y ayudan a proteger componentes internos del chasis y siempre deben estar instaladas en las ranuras vacías del chasis y fuentes de alimentación.

Electrical Storm Warning

To avoid a shock hazard, do not connect or disconnect any cables or perform installation, maintenance, or reconfiguration of this product during an electrical storm.

Français: Ne pas travailler sur le système ni brancher ou débrancher les câbles pendant un orage.

Deutsch: Hinweise bei Unwetter

Um elektrische Schläge zu vermeiden dürfen während eines Gewitters and diesem Gerät keine Kabel angeschlossen oder gelöst werden, sowie keinerlei Installationen, Wartungen oder Konfigurationen vorgenommen werden.

Español: Para evitar peligro de descargas, no conecte o desconecte ningún cable, ni realice ninguna instalación, mantenimiento o reconfiguración de este producto durante una tormenta eléctrica.

Installation Warning

Only personnel knowledgeable in basic electrical and mechanical procedures should install or maintain this equipment.

Français: Toute installation ou remplacement de l'appareil doit être réalisée par du personnel qualifié et compétent.

Deutsch: Installationshinweise

Dieses Gerät soll nur von Personal installiert oder gewartet werden, welches in elektrischen und mechanischen Grundlagen ausgebildet ist.

Español: Estos equipos deben ser instalados y atendidos exclusivamente por personal adecuadamente formado y capacitado en técnicas eléctricas y mecánicas.

Invisible Laser Radiation Warning

Lasers emit invisible radiation from the aperture opening when no fiber-optic cable is connected. When removing cables do not stare into the open apertures. In addition, install protective aperture covers to fiber with no cable connected.

Français: Des radiations invisibles à l'œil nu pouvant traverser l'ouverture du port lorsque aucun câble en fibre optique n'y est connecté, il est recommandé de ne pas regarder fixement l'intérieur de ces ouvertures. Installez les caches connecteurs prévus à cet effet.

Deutsch: Hinweise zur unsichtbaren Laserstrahlung

Die Laser strahlen an der Blendenöffnung unsichtbares Licht ab, wenn keine Glasfaserkabel angeschlossen sind. Blicken Sie nicht in die Öffnungen und installieren Sie unverzüglich die Abdeckungen über den Glasfaseranschlüssen.

Español: Debido a que la apertura del puerto puede emitir radiación invisible cuando no hay un cable de fibra conectado, procurar no mirar directamente a las aperturas para no exponerse a la radiación.

Lithium Battery Warning

There is a danger of explosion if the Lithium battery in your chassis is incorrectly replaced. Replace the battery only with the same or equivalent type of battery recommended by the manufacturer. Dispose of used batteries according to the manufacturer's instructions. The manufacturer's instructions are as follows: Return the module with the Lithium battery to Alcatel-Lucent. The Lithium battery will be replaced at Alcatel-Lucent's factory.

Français: Il y a un danger d'explosion si la batterie de lithium dans votre châssis est remplacée avec une autre ne correspondant pas aux préconisations constructeur. Il faut donc renvoyer le module en réparation chez Alcatel-Lucent qui se chargera de remplacer la batterie.

Deutsch: Hinweise zur Lithium Batterie

Bei falschem Einsetzen der Lithiumbatterie in das Gerät besteht die Gefahr der Explosion. Bitte ersetzen Sie die Batterie nur durch den gleichen bzw. gleichwertigen Typ, empfohlen durch den Hersteller. Benutzte Batterien entsorgen sie bitte wie folgt: Bitte senden Sie das Modul zurück zu Alcatel-Lucent. Dort wird die gebrauchte Batterie ersetzt.

Español: Si substituye las pilas de litio en su chasis, siempre utilice el mismo modelo o el tipo equivalente de pila recomendada por el fabricante. Deshágase de las pilas usadas según las instrucciones del fabricante. Devuelva el módulo con la pila de litio a Alcatel-Lucent. La pila de litio será substituida en la fábrica de Alcatel-Lucent.

Dansk: ADVARSEL! Lithiumbatteri--Eksplosionsfare ved fejlagtig handling. Udskiftning ma kun ske batteri af samme fabrikat og type. Lever det brugte batteri tilbage tilleverandoren.

Operating Voltage Warning

To reduce the risk of electrical shock, keep your hands and fingers out of power supply bays and do not touch the backplane while the switch is operating.

Français: Pour réduire tout risque électrique, gardez vos mains et doigts hors des alimentations et ne touchez pas au fond de panier pendant que le commutateur fonctionne.

Deutsch: Hinweise gegen elektrischen Schlag

Um die Gefahr des elektrischen Schlages zu verringern, greifen sie bitte nicht in die Spannungsversorgung und berühren sie nicht die Rückwandplatine während das Gerät arbeitet.

Español: Para reducir el riesgo de descargas eléctricas, no meta sus manos y dedos dentro del chasis de la fuente de alimentación y no toque componentes internos mientras que el interruptor está conectado.

Power Disconnection Warning

Your switch is equipped with multiple power supplies. To reduce the risk of electrical shock, be sure to disconnect all power connections before servicing or moving the unit.

Français: Il se peut que cette unité soit équipée de plusieurs raccordements d'alimentation. Pour supprimer tout courant électrique de l'unité, tous les cordons d'alimentation doivent être débranchés.

Deutsch: Hinweise zur Spannungsfreischaltung

Ihr Gerät ist mit mehreren Netzteilen ausgerüstet. Um die Gefahr des elektrischen Schlages zu verringern, stellen sie sicher, daß alle Netzverbindungen getrennt sind bevor das Gerät gewartet oder bewegt wird.

Español: Antes de empezar a trabajar con un sistema, asegúrese que el interruptor está cerrado y el cable eléctrico desconectado.

Proper Earthing Requirement Warning

To avoid shock hazard:

- The power cord must be connected to a properly wired and earth receptacle.
- Any equipment to which this product will attached must also be connected to properly wired receptacles.
- Use 12AWG conductor for ground leads connecting the frame to ground and DC return.
- Cleaning and dressing of grounding points during installation is strongly recommended. Also, do not forget the antioxidant.
- To ground the equipment properly, connect a Panduit Corporation UL listed Lug, P/N: LCD8-10A-L to the two threaded holes located on the rear using 8AWG copper conductors. Use Panduit Corporation, P/N: CT-940CH for crimping.

Français:

Pour éviter tout risque de choc électrique:

- Ne jamais rendre inopérant le conducteur de masse ni utiliser l'équipement sans un conducteur de masse adéquatement installé.
- En cas de doute sur la mise à la masse appropriée disponible, s'adresser à l'organisme responsable de la sécurité électrique ou à un électricien.

Deutsch: Hinweise zur geforderten Erdung des Gerätes

Aus Sicherheitsgründen:

- darf das Netzkabel nur an eine Schutzkontaktsteckdose angeschlossen werden.
- dürfen für den Anschluß anderer Geräte, welche mit diesem Gerät verbunden sind, auch nur Schutzkontaktsteckdosen verwendet werden.

Español:

Para evitar peligro de descargas:

- Para evitar peligro de descargas asegúrese de que el cable de alimentación está conectado a una toma de alimentación adecuadamente cableada y con toma de tierra.
- Cualquier otro equipo a cual se conecte este producto también debe estar conectado a tomas de alimentación adecuadamente cableadas.

Read Important Safety Information Warning

The *Getting Started Guide* that accompanied this equipment contains important safety information about which you should be aware when working with hardware components in this system. You should read this guide before installing, using, or servicing this equipment.

Français: Avant de brancher le système sur la source d'alimentation, consultez les directives d'installation disponibles dans le "Getting Started Guide".

Deutsch: Bitte lesen - Sicherheitshinweise

Der Getting Started Guide, welcher diese Anlage beiliegt, enthält wichtige Sicherheitsinformationen, über die sie sich beim Arbeiten mit den Hardwareeinheiten bewußt sein sollten. Sie sollten diese Hinweise lesen, bevor sie installieren, reparieren oder die Anlage verwenden.

Español: La 'Getting Started Guide' que acompañó este equipo contiene información importante de seguridad sobre la cual usted debe estar enterado al trabajar con los componentes de dotación física en este sistema. Usted debe leer esta guía antes de instalar, usar o mantener este equipo.

Restricted Access Location Warning

This equipment should be installed in a location that restricts access. A restricted access location is one where access is secure and limited to service personnel who have a special key, or other means of security.

Français: Le matériel doit être installé dans un local avec accès limité ou seules les personnes habilitées peuvent entrer.

Deutsch: Hinweis zu Umgebungen mit beschränktem Zutritt

Die Anlage sollte an einem Standort mit beschränktem Zutritt installiert sein. Ein Standort mit beschränktem Zutritt stellt sicher, daß dort nur Servicepersonal mit Hilfe eines Schlüssels oder eines anderen Sicherheitssystems Zugang hat.

Español: Este equipo se debe instalar en un sitio con acceso restringido. Un sitio con el acceso restringido es uno seguro y con acceso limitado al personal de servicio que tiene una clave especial u otros medios de seguridad.

Wrist Strap Warning

Because electrostatic discharge (ESD) can damage switch components, you must ground yourself properly before continuing with the hardware installation. For this purpose, Alcatel-Lucent provides a grounding wrist strap and a grounding lug located near the top-right of the chassis. For the grounding wrist strap to be effective in eliminating ESD, the power supplies must be installed in the chassis and plugged into grounded AC outlets.

Français: L'électricité statique (ESD) peut endommager les composants du commutateur. Pour cette raison Alcatel-Lucent joint à l'envoi du châssis un bracelet antistatique à brancher sur la prise mise à la terre située en bas à droite du commutateur. Vous devrez mettre ce bracelet avant toute intervention hardware.

Deutsch: Hinweise zur ESD (Elektrostatischen Aufladung)

Weil elektrostatische Aufladung (ESD) Teile der Anlage beschädigen könnten, müssen sie sich selbst erden, bevor sie mit der Hardware Installation beginnen. Zu diesem Zweck stellt Alcatel-Lucent ein Erdungsarmband und eine Erdungsöse an der oberen rechten Seite des Chassis zur Verfügung. Um eine sichere Erdungsfunktion des Erdungsarmbandes sicherzustellen, müssen die Netzteile installiert und mit dem Schutzleiter des Versorgungsstromkreises verbunden sein.

Español: La descarga electrostática (ESD) puede dañar componentes electrónicos. Usted debe asegurarse que está en contacto con tierra antes de hacer la instalación del equipo. Con este fin, Alcatel-Lucent proporciona una pulsera de muñeca para conectar al chasis en la toma de tierra situada en la parte superior derecha del chasis. Para que la correa de muñeca sea eficaz en la eliminación de ESD, las fuentes de alimentación deben estar instaladas en el chasis y conectadas a enchufes CA con tierra adecuada.

Instrucciones de seguridad en español

Advertencia sobre el levantamiento del chasis

Se requieren dos personas para levantar el chasis. Debido a su peso, la elevación del chasis sin ayuda puede causar daños corporales. También es seguro doblar sus rodillas y guardar su espalda derecho al ayudar a levantar el chasis.

Advertencia de las tapaderas en blanco

Porque regulan la circulación de aire y ayudan a proteger componentes internos del chasis, las tapaderas en blanco deben seguir instaladas en las ranuras vacías del módulo y la fuente de alimentación siempre.

Advertencia en caso de tormenta eléctrica

Para evitar peligro de descargas, no conecte o desconecte ningún cable, ni realice ninguna instalación, mantenimiento o reconfiguración de este producto durante una tormenta eléctrica.

Advertencia de instalación

Solamente el personal bien informado en procedimientos eléctricos y mecánicos básicos debe instalar o mantener este equipo.

Advertencia de radiación láser invisible

Los lasers emiten radiación invisible de la apertura abierta cuando no se conecta ningún cable de fibra óptica. Al quitar los cables no mire fijamente en las aberturas abiertas. Además, instale las cubiertas protectoras de la apertura a las salidas de la fibra sin el cable conectado.

Advertencia de la batería de litio

Hay un peligro de la explosión si la batería del litio en su chasis se substituye incorrectamente. Substituya la batería solamente por el mismo o el equivalente de tipo de batería recomendado por el fabricante. Deseche las baterías usadas según las instrucciones del fabricante. Las instrucciones del fabricante son como sigue: Devuelva el módulo con la batería del litio a Alcatel-Lucent. La batería del litio será substituida en la fábrica de Alcatel-Lucent.

Advertencia sobre la tensión de operación

Para reducir el riesgo del choque eléctrico, mantenga sus manos y dedos fuera de la fuente de alimentación y no toque la placa madre mientras que el interruptor está funcionando.

Advertencia sobre la desconexión de la fuente

Su interruptor esta equipado por fuentes de alimentación múltiples. Para reducir el riesgo de choque eléctrico, asegúrese desconectar todas las conexiones de alimentación antes de mantener o de mover la unidad.

Advertencia sobre una apropiada conexión a tierra

Para evitar peligro de descargas:

- El cable de alimentación debe estar conectado a una toma de alimentación adecuadamente cableada y con toma de tierra.

Cualquier equipo al cual se conecte este producto debe estar también conectado a tomas de alimentación adecuadamente cableadas.

Leer “información importante de seguridad”

La *Guía de “Comenzando a Usar”* que acompaña este equipo contiene información importante de seguridad sobre la cual usted debe saber al trabajar con los componentes de dotación física en este sistema. Usted debe leer esta guía antes de instalar, de usar, o de mantener este equipo.

Advertencia de acceso restringido

Este equipo se debe instalar en una ubicación que restrinja el acceso. Una ubicación con acceso restringido es una donde está seguro y limitado el acceso al personal de servicio que tiene un clave especial, u otros medios de la seguridad.

Advertencia de pulsera antiestática

Debido a que la descarga electrostática (ESD) puede dañar componentes del interruptor, usted debe conectarse a tierra correctamente antes de continuar con la instalación del equipo. Para este propósito, Alcatel-Lucent proporciona una pulsera antiestática y un terminal que pone a tierra situados cerca de la parte superior derecha del chasis. Para que la pulsera antiestática sea eficaz en la eliminación de ESD, las fuentes de alimentación se deben instalar en el chasis y enchufar en las salidas de CA con descarga a tierra.

Clase de seguridad

Cumple con 21CFR 1040.10 y 1040.11 ó sus equivalentes.

Index

A

- availability 1-4
 - hardware monitoring 1-5
 - hot swapping 1-4
 - software rollback 1-4

B

- boot serialbaudrate** command 5-2
- boot serialparity** command 5-2
- boot serialtopbits** command 5-3
- boot serialwordsize** command 5-2
- boot.params** command 5-3

C

- chassis
 - airflow 3-4
 - booting 5-1
 - monitoring 5-5
 - OS6855-24 front panel 2-4
 - OS6855-U10 front panel 2-13
 - OS6855-U24 front panel 2-7, 2-10
 - rear panel 2-18
- chassis types
 - OS6855-24 2-4
 - OS6855-U10 2-13
 - OS6855-U24 2-7, 2-10
- commit file** command 5-3
- commit system** command 5-3
- console port 2-40, 2-41, 5-2
 - default settings 2-40, 5-2
 - modifying default settings 5-2

D

- DC power supplies 2-37
- defaults
 - PoE 6-5

E

- exit** command 5-3

H

- hardware monitoring 1-5, 5-5
 - automatic 1-5
 - LEDs 1-5, 5-7
 - user-driven 1-5
- hot swapping 1-4

I

- image rollback
 - see* software rollback
- Inline Power
 - see* PoE

L

- lanpower maxpower** command 6-7
- lanpower power** command 6-6
- lanpower priority** command 6-7
- lanpower priority-disconnect** command 6-8
- lanpower start** command 6-5
- lanpower stop** command 6-5
- LEDs
 - see* hardware monitoring

M

- modify boot parameters** command 5-2

O

- OmniSwitch 6855-14
 - technical specifications 2-12
- OmniSwitch 6855-24
 - technical specifications 2-6
- OmniSwitch 6855-U10
 - technical specifications 2-15
- OmniSwitch 6855-U24 2-10
 - technical specifications 2-9
- OS6855-24
 - see* OmniSwitch 6855-24
- OS6855-U10
 - see* OmniSwitch 6855-U10
- OS6855-U24
 - see* OmniSwitch 6855-U24

P

- pinouts 2-41
- PoE 6-1
 - defaults 6-5
 - monitoring 6-4, 6-11
 - priority disconnect 6-8
 - specifications 6-3
- PoE Power Shelf
 - monitoring 6-4
- power cord
 - specifications 2-36
- power cords 2-36
- Power on LAN
 - see* PoE
- Power over Ethernet
 - see* PoE
- Power over LAN
 - see* PoE
- power supplies
 - PS-126180AC AC power supply 2-22
- power supply

connecting a DC power source 2-37
power supply shelf 2-35

S

show command 5-3
show chassis command 5-5
show cmm command 5-6
show fan command 5-6
show lanpower command 6-11
show module command 5-6
show module long command 5-6
show module status command 5-6
show ni command 5-6
show power command 5-4
show temperature command 5-5
software rollback 1-4
specifications
 PoE 6-3
 power cord 2-36
status
 LEDs 2-16
Status LED Table 2-17
Status LEDs 2-16

T

technical specifications
 console port 2-40, 2-41, 5-2
 OmniSwitch 6855-14 2-12
 OmniSwitch 6855-24 2-6
 OmniSwitch 6855-U10 2-15
 OmniSwitch 6855-U24 2-9
 pinouts 2-41